

Village of Mukwonago
Notice of Meeting and Agenda

COMMITTEE OF THE WHOLE MEETING
Wednesday, April 2, 2025

Time: **5:30 pm**

Place: **Mukwonago Municipal Building/Board Room, 440 River Crest Court**

1. Call to Order

2. Roll Call

3. Comments from the Public

Information and comment may be received from the public by the Committee of the Whole, but solely as to matters that appear on the Agenda for that meeting. The public comment session shall last no longer than 15 minutes and individual presentations are limited to (3) minutes per speaker. These time limits may be extended at the discretion of the Chief Presiding Officer. The Committee of the Whole may have limited discussion on the information received, however, no action will be taken on issues raised during the public comment session unless they are otherwise on the agenda for that meeting. Public comments should be addressed to the Committee of the Whole as a body. Presentations shall not deal in personalities or personal attacks on members of the Board, the applicant for any project or Village employees. Comments, questions and concerns shall be presented in a respectful and professional manner. Any questions to an individual member of the Committee of the Whole or Staff will be deemed out of order by the Presiding Officer.

4. Presentation

- 4.1 2025 National Public Safety Telecommunicators Week Proclamation
[2025 National Public Safety Telecommunicators Week](#)

5. Approval of Minutes

- 5.1 Approve Committee of the Whole minutes from March 5, 2025
[March 5, 2025 DRAFT COW Minutes.docx](#)

6. Finance Committee, Trustee Darlene Johnson

Discussion and action possible on the following items.

- 6.1 Discussion/Recommendation to approve the purchase requisition for two (2)
International 507 TA patrol truck cab and chassis
[2026 International Patrol Trucks \(2\) PR.pdf 2.pdf](#)
[Mukwonago, Village of-HV507 TA Patrol-86CA-25573-02-031725.pdf](#)
[Mukwonago, Village of-HV507 TA Patrol-100CA-25573-01-031725.pdf](#)

- 6.2 Discussion/Recommendation to approve the Village Board to approve Vouchers in
the amount of \$1,407,294.80
[2025-04-02 COW AP Packet.pdf](#)

- 6.3 Monthly Treasury Report and Revenue/Expenditure Guideline Report For February
(For information purposes only, no action required)

[2025-02 February Revenue & Expenditure.pdf](#)

[2025-02 February Treasury Report.pdf](#)

7. **Health and Recreation Committee, Trustee John Meiners**

Discussion and action possible on the following items

- 7.1 Discussion/Recommendation regarding a Special Event Permit Application filed by Clarendon Avenue Elementary School for the event of Clarendon Art Show to take place on May 22, 2025; to include closure of Clarendon Ave, from E Veterans Way to Lincoln Ave
[Claredon School Special Event Permit.pdf](#)
- 7.2 Discussion/Recommendation regarding a Special Event Permit Application filed by Chris Hill for the event of 70's & 80's Class Reunion, to take place on August 30, 2025 from 1:00 p.m. to 9:00 p.m., located in Field Park
[Special Event- Class Reunion- Field Park.pdf](#)
- 7.3 Discussion/Recommendation to approve the Phantom Glen Park ADA fishing pier decking
[AICR Phantom Glen Park ADA Fishing Pier.pdf](#)
[Home Run Quote.pdf](#)
[Est_1288_from_Caspers_Improvements_5352.pdf](#)
[Phantom Glen Park Pier Renovation 2025-03-19.pdf](#)
- 7.4 Discussion/Recommendation regarding a Special Event Permit Application filed by Mukwonago American Legion Post #375 for the Memorial Day Parade to be held on May 26, 2025 from 9:00 am to Noon, located on N Rochester St
[Special Event Permit- Memorial Day Parade.pdf](#)
- 7.5 Discussion/Recommendation regarding a Special Event Permit filed by the American Legion Post #375 for Maxwell Street Days to take place on June 7 & 8, July 19 & 20, August 16 & 17, and September 13 & 14, from 6:00 am to 5:00 pm each day, located at Field Park
[Special Event Permit- Maxwell Street Days.pdf](#)
- 7.6 Discussion regarding potential public Wi-Fi for public facilities

8. **Judicial Committee, Trustee Dale Porter**

Discussion and action possible on the following items

- 8.1 Discussion/Recommendation regarding **Ordinance 1035** an Ordinance to Allow Electronic "Reader Board" Signs to Refresh at a Rate of Once Every Fifteen Seconds
[24D8739-Ordinance to allow electronic reader board signs to change every 15 seconds.DOCX](#)

- 8.2 Discussion/Recommendation regarding an Original Class "B" Beer License Application filed by Najera Brothers Company LLC d/b/a Genoas Pizza, agent Bulfrano Najera, located at 225 Bayview Rd, Ste #500, Mukwonago

[Genoa Pizza Class B Beer Application.pdf](#)

- 8.3 Discussion/Recommendation regarding an application for a Temporary Class "B"/"Class B" Retailer's License filed by the American Legion Post #375 for Maxwell Street Days to take place on June 7 & 8, July 19 & 20, August 16 & 17, and September 13 & 14, from 6:00 am to 5:00 pm each day, located at Field Park

[Maxwell Street Days- Temp Retailer's License.pdf](#)

- 8.4 Discussion/Recommendation regarding an application for a Temporary Class "B"/"Class B" Retailer's License filed by the Rotary Club of Mukwonago for the Phantom Stage Concerts to take place July 3, 2025, August 9, 2025, and September 20, 2025, located at Phantom Junction Stage

[Rotary - Temporary Retailer's.pdf](#)

9. Personnel Committee, Trustee Ken Johnson

- 9.1 Discussion/Recommendation regarding the appointment of a negotiation team for the Professional Fire Union Contract Services to expire 12/31/2025 (*tabled at March 19, 2025 Village Board Meeting*)

[Union Negotiations Request Letter](#)

10. Protective Services, Trustee Scott Reeves

- 10.1 Update regarding cell phone 911 call conversion

11. Library Board of Trustees, Trustee Eric Brill

- 11.1 March 2025 Library Director's Report (*For information only, no action required*)

[2025-03_The_Directors_Report_March.pdf](#)

12. Public Works Committee, Trustee Eric Brill

Discussion and action possible on the following items

- 12.1 Discussion/Recommendation to grant permission for the log cabin restoration as presented by the Mukwonago Historical Society and Museum

[Log Cabin Restoration.pdf](#)

- 12.2 Discussion/Recommendation regarding a bid award to Parking Lot Maintenance, LLC for the Field Park Pickleball Court construction, in an amount not to exceed \$132,894.48

[Field Park Pickleball Court- Recommendation of Award.pdf](#)

- 12.3 Discussion/Recommendation regarding Task Order #2025-04 to provide engineering and construction related to services for the design, bidding, and construction of extension of East Wolf Run

[2025-04 East Wolf Run Extension Task Order.pdf](#)

12.4 Discussion/Recommendation regarding Task Order #2025-05 to provide engineering and construction related to services for the design, bidding, and construction of extension of Marsh View Drive

[2025-05 Marsh View Drive Extension Task Order.pdf](#)

12.5 Discussion/Recommendation to approve the Mukwonago Shared Connectivity Network MOU (fiber network sharing)

[AICR Fiber MOU.pdf](#)

[MSCN MOU.pdf](#)

12.6 Discussion/Recommendation to provide a credit for the sewer usage due to leaking yard hydrant for 419 Lake St

[AIRF_Sewer Credit Request_419 Lake St.pdf](#)

12.7 Update on Intergovernmental East Troy Multi-use Trail Project

13. Adjournment

It is possible that a quorum of, members of other governmental bodies of the municipality may be in attendance at the above stated meeting to gather information. No action will be taken by any governmental body at the above stated meeting other than the governmental body specifically referred to above in this notice. Please note, upon reasonable notice, efforts will be made to accommodate the needs of individuals with disabilities through appropriate aids and services. For additional information or to request this service, contact the Municipal Clerk's Office, (262) 363-6420.

Proclamation

2025 National Public Safety Telecommunicators Week

Whereas emergencies can occur at anytime that require police, fire, or emergency medical services;

And Whereas when an emergency occurs, the prompt response of police officers, firefighters and paramedics is critical to the protection of life and preservation of property;

And Whereas the safety of our police officers is dependent upon the quality and accuracy of information obtained from citizens who telephone the Mukwonago Dispatch Center;

And Whereas Public Safety Telecommunicators are the first and most critical contact our citizens have with emergency services;

And Whereas Public Safety Telecommunicators are the single vital link for our police officers by monitoring their activities by radio, providing them information, and insuring their safety;

And Whereas while enduring long hours, abnormal schedules, and handling frequent life and death emergencies, the Village of Mukwonago 911 Dispatch Center sets high standards in performing their duties in a dedicated, diligent, and compassionate manner;

And Whereas our Public Safety Communications personnel serve the public daily in countless ways without due recognition by the beneficiaries of their services;

Therefore, Be It Resolved that Fred H. Winchowky, Village President of Mukwonago, declares the week of April 13th – 19th, 2025 to be National Public Safety Telecommunicators Week in Mukwonago, in honor of Deborah Zaeske, Brenda DiMaggio, Italia Hench, Nicole Robertson, Doris Dietzler, Victoria Weber, and Joshua Adams whose diligence and professionalism keep our Village and citizens safe.

Dated this 2nd day of April, 2025.

Fred H. Winchowky, Village President



ATTEST:

Lana Kropf, Village Clerk-Treasurer

MINUTES OF THE COMMITTEE OF THE WHOLE MEETING

Wednesday, March 5, 2025

Time: **5:30 pm**

Place: **Mukwonago Municipal Building/Board Room, 440 River Crest Court**

Call to Order

President Winchowky called the meeting to order at 5:30 p.m.

Roll Call

Present: Brill, D. Johnson, K. Johnson, Meiners, Reeves, and President Winchowky

Absent: Porter (excused)

Comments from the Public

NONE

Approval of Minutes

Approval of the Committee of the Whole minutes of February 5, 2025

D. Johnson made an amendment to the minutes, under Finance Committee item 5.5, to specifically note that, of the \$6,118,817.25, \$5,250,231.31 was allocated to Waukesha County for the tax settlement. Motion by Johnson to approve the Committee of the Whole minutes of February 5, 2025 as amended, second by Reeves. Motion carried 6-0.

Finance Committee, Trustee Darlene Johnson

Discussion/Recommendation to approve the Economic Development Cooperative Contract between Waukesha County Center for Growth, Inc and the Village of Mukwonago

Administrator Dykstra stated that this is an annual contract with no rates change for the current year. Motion by D. Johnson to recommend approval, second by Meiners. President Winchowky stated that there is a misprint on page 13 of the contract, that needs to be corrected. Motion carried 6-0.

Discussion/Recommendation to apply for a loan with Citizens Bank to fund the Sewer Utility's 2025 Capital budget items

Finance Director Doherty stated this is for the capital sewer projects that wouldn't warrant another large borrowing.

Motion by D. Johnson to recommend approval, second by Meiners. Motion carried 6-0.

Discussion/Recommendation to approve Vouchers in the amount of \$3,722,132.49

D. Johnson stated that the majority of accounts payable (\$2,505,844.58) is for the property tax settlement.

Motion by D. Johnson to recommend approval, second by K. Johnson. Motion carried 6-0.

Discussion/Action regarding Resolution 2025-02 amending the 2024 Adopted Budgets for Fire/Ambulance Fund, Fire/Ambulance Designated Fund, Community Development Fund, TID #5, Debt Service Fund, American Rescue Plan Act Fund, Library Fund and Parkland Fund

Finance Director Doherty stated that this is to balance the budget, with any overages, that was passed for 2024. She outlined the different funds, as described in the packet.

Motion by D. Johnson to recommend approval, second by Reeves. Motion carried 6-0.

Discussion/Recommendation to approve the Village Hall Community room AC system

DPW Director Bittner stated price had increased by approximately \$5,000 from what the original quoted.

Motion by D. Johnson to recommend approval \$26,195.00, second by Meiners. Motion carried 6-0.

Discussion/Recommendation to approve the Holz Parkway bridge deck sealing purchase requisition

DPW Director Bittner explained the process for the work to be done. He noted that the work to be done is due to normal wear and that it shouldn't take more than a couple of days.

Motion by D. Johnson to recommend approval, second by Reeves. Motion carried 6-0.

Monthly Treasury Report and Revenue/Expenditure Guideline Report For January 2025

For information only. No action taken.

Health and Recreation Committee, Trustee John Meiners

Discussion/Recommendation regarding a Special Event Permit Application filed by the Village of Mukwonago Police Department for the event of National Night Out 2025 to be held on August 5, 2025 from 5:30 p.m. to 8:00 p.m., located at Field Park

Motion by Meiners to recommend approval, second by Reeves. Trustee K. Johnson noted that there will be planning meeting for this event. Motion carried 6-0.

Discussion/Recommendation regarding a Special Event Permit Application filed by Parabolic Pictures INC to take place June 6 and June 7, 2025, from 7:00 p.m. to 7:00 a.m. (through the night), to take place at Phantom Glen Park

Motion by Meiners to recommend approval, second by Brill. Discussion was held concerning the a type of movie, but it was unknown. Motion carried 6-0.

Discussion/Recommendation regarding a Special Event Permit filed by Mukwonago Community Library for the event of Summer Library Program, to take place on June 14, 2025 from 10:00 a.m. to Noon, located in Washington Avenue Park

Motion by to recommend approval, second by D. Johnson. No discussion. Motion carried 6-0.

Judicial Committee, Trustee Dale Porter

Discussion/Recommendation to amend Chapter 64 regarding Reader Board Signs to change the interval timing for an electronic message display change

Administrator Dykstra stated that this was brought to her attention by Trustee Porter. She noted the discrepancies of adherence to the sign code, and it seems to not be followed currently. The code currently states limits messages one minute before it can change and most municipalities state that signs can change every four to five seconds.

Trustee Brill recommended that this item go before the Plan Commission for a recommendation. No action taken.

Library Board of Trustees, Trustee Eric Brill

Library Directors Report for February 2025

For information only. Trustees Brill announced that upcoming events as listed the packet materials. No action taken.

Public Works Committee, Trustee Eric Brill

Discussion/Recommendation regarding Change Order #8 filed by Musson Bros, INC (via Ruckert & Mielke INC) for the DeBack Drive Infrastructure Project in an amount not to exceed \$185,166.31

Motion by Brill to recommend approval, second by Meiners. Brill explained that this change order is related to the renamed of DeBack Drive to Donna Drive. Motion carried 6-0.

Discussion/Recommendation regarding Task Order #2020-02A1 filed by Ruekert & Mielke INC for the DeBack Drive Infrastructure Construction Related Services - Amendment #1 in an amount not to exceed \$179,730.00

Motion by Brill to recommend approval, second by K. Johnson. This item is to cover inflation costs. Motion carried 6-0.

Discussion/Recommendation regarding the awarding the Primary Clarifier Rehab Project Bid to Staab Construction in an amount not to exceed \$74,000.00

Motion by to recommend approval, second by K. Johnson. Brill stated that this is to update the clarifying system. Motion carried 6-0.

Closed Session

Closed session pursuant to Wis. Stats. § 19.85(1)(c) (Compensation and Evaluation. Considering employment, promotion, compensation or performance evaluation data of any public employee subject to the jurisdiction or authority of governing body.) concerning Village Administrator Evaluation

Motion by Meiners to convene the Committee into Closed Session, second by D. Johnson. Motion carried on a roll call vote 6-0. The meeting convened into Closed Session at 6:12 p.m.

Reconvene into Open Session

Motion to reconvene into open session pursuant to Wis. Stats. §19.85(2) for possible discussion and/or action concerning any matter discussed in closed session

Motion by Meiners to convene the Committee into Open Session, second by Reeves. Motion carried on a roll call vote 6-0. The meeting reconvened into Open Session at 6:46 p.m.

Adjournment

Meeting adjourned at 6:47 p.m.

VILLAGE OF MUKWONAGO PURCHASE REQUISITION

PLEASE TYPE OR PRINT IN INK CLEARLY ON THIS FORM

DATE:	3/17/25	NUMBER:	
--------------	---------	----------------	--

VENDOR NAME & ADDRESS:	SHIP TO:
Lakeside INTL, LLC 11000 W Silver Spring Rd. Milwaukee, WI 53225	DPW

DEPT NAME:	SUGGESTED VENDOR	AUTHORIZED SIGNATURE
DPW	Lakeside INTL, LLC 11000 W Silver Spring Rd. Milwaukee, WI 53225	

BUDGETED ITEM?	Yes	BUDGETED SOURCE:	
-----------------------	-----	-------------------------	--

<u>ITEM</u>	<u>QTY</u>	<u>DESCRIPTION</u>	<u>UNIT PRICE</u>	<u>AMOUNT</u>	<u>ACCT #</u>
1	1	2026 HV507 TA INT Chassis 86 Inch CA Wheelbase		\$122,367.00	
2	1	2026 HV507 TA INT Chassis 100 Inch CA Wheelbase		\$122,367.00	
			TOTAL	\$244,734.00	430-5700- 271200

FINANCE COMMITTEE USE ONLY	
APPROVED (COMMITTEE INITIALS):	
DATE:	
SPECIAL INSTRUCTIONS	



HV507 SFA

Sales Proposal For:
Village of Mukwonago

Presented By:
LAKESIDE INTL, LLC

Prepared For:

Village of Mukwonago
 Ron Bittner
 440 Rivercrest Ct.
 Mukwonago, WI 53149-1759
 (262)363 - 6420
 Reference ID: SW 86" CA

Presented By:

LAKESIDE INTL, LLC
 Patrick McNamara
 11000 W SILVER SPRING RD
 MILWAUKEE WI 53225 -
 (414)353-4800

Thank you for the opportunity to provide you with the following quotation on a new International truck. I am sure the following detailed specification will meet your operational requirements, and I look forward to serving your business needs.

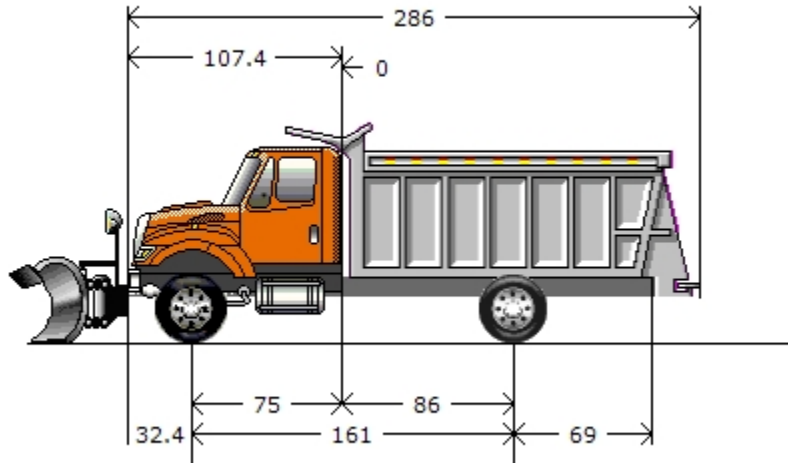

Model Profile
2026 HV507 SFA (HV507)

AXLE CONFIG: 4X2
APPLICATION: Front Plow and Wing with Spreader
MISSION: Requested GVWR: 43000. Calc. GVWR: 43000. Calc. GCWR: 80000
 Calc. Start / Grade Ability: 37.44% / 2.95% @ 55 MPH
 Calc. Geared Speed: 66.8 MPH
DIMENSION: Wheelbase: 161.00, CA: 86.00, Axle to Frame: 69.00
ENGINE, DIESEL: {Cummins L9 330} EPA 2024, 330HP @ 2200 RPM, 1000 lb-ft Torque @ 1200 RPM, 2200 RPM Governed Speed, 330 Peak HP (Max)
TRANSMISSION, AUTOMATIC: {Allison 3500 RDS} 6th Generation Controls, Wide Ratio, 6-Speed with Double Overdrive, with PTO Provision, Less Retarder, Includes Oil Level Sensor, with 80,000-lb GVW and GCW Max, On/Off Highway
CLUTCH: Omit Item (Clutch & Control)
AXLE, FRONT NON-DRIVING: {Meritor MFS-20-133A} Wide Track, I-Beam Type, 20,000-lb Capacity
AXLE, REAR, SINGLE: {Meritor RS-23-160} Single Reduction, 23,000-lb Capacity, Driver Controlled Locking Differential, 200 Wheel Ends Gear Ratio: 6.14
CAB: Conventional, Day Cab
TIRE, FRONT: (2) 315/80R22.5 Load Range L HAU 3 WT (CONTINENTAL), 480 rev/mile, 68 MPH, All-Position
TIRE, REAR: (4) 11R22.5 Load Range H HDW2 (CONTINENTAL), 495 rev/mile, 75 MPH, Drive
SUSPENSION, REAR, AIR, SINGLE: {Hendrickson PRIMAAX EX} 23,000-lb Capacity, 9.0" Ride Height, with Shock Absorbers
PAINT: Cab schematic 100WK
 Location 1: 0311, Omaha Orange (Std)
 Chassis schematic N/A

Code	Description
HV50700	Base Chassis, Model HV507 SFA with 161.00 Wheelbase, 86.00 CA, and 69.00 Axle to Frame.
1570	TOW HOOK, FRONT (2) Frame Mounted
1ANA	AXLE CONFIGURATION 4x2
	<u>Notes</u> : Pricing may change if axle configuration is changed.
1CAJ	FRAME RAILS Heat Treated Alloy Steel (120,000 PSI Yield); 10.866" x 3.622" x 0.437" (276.0mm x 92.0mm x 11.1mm); 456.0" (11582mm) Maximum OAL
1LLA	BUMPER, FRONT Swept Back, Steel, Heavy Duty
1WDS	FRAME EXTENSION, FRONT Integral; 20" In Front of Grille
1WEV	WHEELBASE RANGE 146" (370cm) Through and Including 195" (495cm)
1WRN	BRACKET, CAB MOUNT Heavy Duty
2ARY	AXLE, FRONT NON-DRIVING {Meritor MFS-20-133A} Wide Track, I-Beam Type, 20,000-lb Capacity
3AHU	SUSPENSION, FRONT, SPRING Multi-Stage Parabolic Taper Leaf, Shackle Type, 20,000-lb Capacity, with Shock Absorbers
4091	BRAKE SYSTEM, AIR Dual System for Straight Truck Applications
	<u>Includes</u> : BRAKE LINES Color and Size Coded Nylon : DRAIN VALVE Twist-Type : GAUGE, AIR PRESSURE (2) Air 1 and Air 2 Gauges; Located in Instrument Cluster : PARKING BRAKE CONTROL Yellow Knob, Located on Instrument Panel : PARKING BRAKE VALVE For Truck : QUICK RELEASE VALVE On Rear Axle for Spring Brake Release: 1 for 4x2, 2 for 6x4 : SPRING BRAKE MODULATOR VALVE R-7 for 4x2, SR-7 with relay valve for 6x4/8x6
4619	TRAILER CONNECTIONS Four-Wheel, with Hand Control Valve and Tractor Protection Valve, for Straight Truck
	<u>Notes</u> : When electronic stability control is ordered with trailer connections on a 4x2 truck, please check the operator manual for trailer weight restrictions.
4732	DRAIN VALVE {Berg} with Pull Chain, for Air Tank
4AZA	AIR BRAKE ABS {Bendix AntiLock Brake System} 4-Channel (4 Sensor/4 Modulator) Full Vehicle Wheel Control System
4EBT	AIR DRYER {Bendix AD-IP} with Heater
4EXU	BRAKE CHAMBERS, REAR AXLE {Bendix EverSure} 30/30 SqIn Spring Brake
4EXV	BRAKE CHAMBERS, FRONT AXLE {Bendix} 24 SqIn
4GBM	BRAKE, PARKING Manual Push-Pull Pneumatic Parking Brake
4LAA	SLACK ADJUSTERS, FRONT {Haldex} Automatic
4LGA	SLACK ADJUSTERS, REAR {Haldex} Automatic
4SPA	AIR COMPRESSOR {Cummins} 18.7 CFM
4VKC	AIR DRYER LOCATION Mounted Inside Left Rail, Back of Cab
4WBX	DUST SHIELDS, FRONT BRAKE for Air Cam Brakes
4WDM	DUST SHIELDS, REAR BRAKE for Air Cam Brakes

Code	Description
4WZJ	AIR TANK LOCATION (2) : One Mounted Under Each Rail, Front of Rear Suspension, Parallel to Rail
4XDR	BRAKES, REAR {Meritor 16.5X7 Q-PLUS CAST} Air S-Cam Type, Cast Spider, Fabricated Shoe, Double Anchor Pin, Size 16.5" X 7", 23,000-lb Capacity per Axle
4XDT	BRAKES, FRONT {Meritor 16.5X6 Q-PLUS CAST} Air S-Cam Type, Cast Spider, Fabricated Shoe, Double Anchor Pin, Size 16.5" X 6", 23,000-lb Capacity
5710	STEERING COLUMN Tilting and Telescoping
5CAW	STEERING WHEEL 4-Spoke; 18" Dia., Black
5PTB	STEERING GEAR (2) {Sheppard M100/M80} Dual Power
6DGG	DRIVELINE SYSTEM {Dana Spicer} 1710, for 4x2/6x2
7BES	AFTERTREATMENT COVER Polished Aluminum
7BLW	EXHAUST SYSTEM Horizontal Aftertreatment System, Frame Mounted Right Side Under Cab, for Single Vertical Tail Pipe, Frame Mounted Right Side Back of Cab
7WBA	TAIL PIPE (1) Turnback Type, Bright
7WBS	MUFFLER/TAIL PIPE GUARD (1) Bright Stainless Steel
7WCM	EXHAUST HEIGHT 8' 10"
8000	ELECTRICAL SYSTEM 12-Volt, Standard Equipment
	<u>Includes</u>
	: DATA LINK CONNECTOR For Vehicle Programming and Diagnostics In Cab
	: HAZARD SWITCH Push On/Push Off, Located on Instrument Panel to Right of Steering Wheel
	: HEADLIGHT DIMMER SWITCH Integral with Turn Signal Lever
	: PARKING LIGHT Integral with Front Turn Signal and Rear Tail Light
	: STARTER SWITCH Electric, Key Operated
	: STOP, TURN, TAIL & B/U LIGHTS Dual, Rear, Combination with Reflector
	: TURN SIGNAL SWITCH Self-Cancelling for Trucks, Manual Cancelling for Tractors, with Lane Change Feature
	: WINDSHIELD WIPER SWITCH 2-Speed with Wash and Intermittent Feature (5 Pre-Set Delays), Integral with Turn Signal Lever
	: WINDSHIELD WIPERS Single Motor, Electric, Cowl Mounted
	: WIRING, CHASSIS Color Coded and Continuously Numbered
8695	SNOW SHIELD (2) Chrome; for Dual Air Horns
8899	JUMP START STUD (2) 12V, Remote Mounted
8GXD	ALTERNATOR {Leece-Neville AV1160P2013} Brush Type, 12 Volt, 160 Amp Capacity, Pad Mount, with Remote Sense
8HAB	BODY BUILDER WIRING Back of Day Cab at Left Frame or Under Sleeper, Extended or Crew Cab at Left Frame; Includes Sealed Connectors for Tail/Amber Turn/Marker/ Backup/Accessory Power/Ground and Sealed Connector for Stop/Turn
8HAH	ELECTRIC TRAILER BRAKE/LIGHTS Accommodation Package to Rear of Frame; for Combined Trailer Stop, Tail, Turn, Marker Light Circuits; Includes Electric Trailer Brake Accommodation Package with Cab Connections for Mounting Customer Installed Electric Brake Unit, Less Trailer Socket
8HXT	HORN, AIR (2) Single Tone, Chrome, Roof Mounted, with Lanyard Pull Cord
8MMZ	BATTERY SYSTEM {Fleetrite AGM-GP31} Maintenance-Free, (3) AGM 12-Volt 2475CCA Total, Top Threaded Stud
8RGA	2-WAY RADIO Wiring Effects; Wiring with 20 Amp Fuse Protection, Includes Ignition Wire with 5 Amp Fuse, Wire Ends Heat Shrink and Routed to Center of Header Console in Cab

Code	Description
8RMZ	SPEAKERS (2) 6.5" Dual Cone Mounted in Both Doors, (2) 5.25" Dual Cone Mounted in Both B-Pillars
8RPP	ANTENNA Shark Fin, Roof Mounted
8RPS	RADIO AM/FM/WB/Clock/Bluetooth/USB Input/Auxiliary Input
8THB	BACK-UP ALARM Electric, 102 dBA
8THJ	AUXILIARY HARNESS 3.0' for Auxiliary Front Head Lights and Turn Signals for Front Plow Applications
8TKK	TRAILER AUXILIARY FEED CIRCUIT for Electric Trailer Brake Accommodation/Air Trailer ABS; with 30 Amp Fuse and Relay, Controlled by Ignition Switch
8VAY	HORN, ELECTRIC Disc Style
8WGL	WINDSHIELD WIPER SPD CONTROL Force Wipers to Slowest Intermittent Speed When Park Brake Set and Wipers Left on for a Predetermined Time
8WPH	CLEARANCE/MARKER LIGHTS (5) {Truck Lite} Amber LED Lights, Flush Mounted on Cab or Sunshade
8WPZ	TEST EXTERIOR LIGHTS Pre-Trip Inspection will Cycle all Exterior Lamps Except Back-up Lights
8WRB	HEADLIGHTS ON W/WIPERS Headlights Will Automatically Turn On if Windshield Wipers are Turned On
8WTK	STARTING MOTOR {Delco Remy 38MT Type 300} 12 Volt, Less Thermal Over-Crank Protection
8WWJ	INDICATOR, LOW COOLANT LEVEL with Audible Alarm
8WXD	ALARM, PARKING BRAKE Electric Horn Sounds in Repetitive Manner When Vehicle Park Brake is "NOT" Set, with Ignition "OFF" and any Door Opened
8XAH	CIRCUIT BREAKERS Manual-Reset (Main Panel) SAE Type III with Trip Indicators, Replaces All Fuses
8XDZ	BATTERY BOX Steel, 2-3 Battery Capacity, Mounted Inside the Cab, Under Passenger Seat
8XGT	TURN SIGNALS, FRONT Includes LED Side Turn Lights Mounted on Fender
8XNY	HEADLIGHTS Halogen
8XPK	POWER SOURCE, ADDITIONAL Auxiliary Power Outlet (APO) with USB-A Port and USB-C Port, Located in the Instrument Panel
9585	FENDER EXTENSIONS Rubber
9AAB	LOGOS EXTERIOR Model Badges
9AAE	LOGOS EXTERIOR, ENGINE Badges
9ANG	HOOD, HATCH (01) for Servicing
9HAN	INSULATION, UNDER HOOD for Sound Abatement
9HBM	GRILLE Stationary, Chrome
9HBN	INSULATION, SPLASH PANELS for Sound Abatement
9WBC	FRONT END Tilting, Fiberglass, with Three Piece Construction, for WorkStar/HV
10021	CHASSIS COATING Corrosion Resistant E-Coat Primer Coating for Single Frame Rails
10060	PAINT SCHEMATIC, PT-1 Single Color, Design 100
	<u>Includes</u> : PAINT SCHEMATIC ID LETTERS "WK"
10761	PAINT TYPE Base Coat/Clear Coat, 1-2 Tone
10AGB	COMMUNICATIONS MODULE Telematics Device with Over the Air Programming; Includes Five Year Data Plan and International 360

Code	Description
10JPA	CUSTOMER IDENTITY for Sourcewell
10SLV	PROMOTIONAL PACKAGE Government Silver Package
10UAV	VEHICLE REGISTRATION IDENTITY ID for Non-CARB Omnibus and/or Non-ACT Adopting State or Exempt Vehicle. Not for use on vehicles registering in CA/MA /OR/NJ/NY/WA. Contains non-mitigated legacy engine & cannot be registered in CA unless exempt. You may be held liable under state law for failure to properly register vehicle.
	<u>Notes</u> : CANNOT BE REGISTERED IN CA. For vehicles that will be registered in States other than CA.
10WBS	KEYS - ALL ALIKE, ADDITIONAL 2 Keys
10WKN	KEYS - ALL ALIKE, ID I-1624 Compatible with Z-250
11001	CLUTCH Omit Item (Clutch & Control)
12703	ANTI-FREEZE Red, Extended Life Coolant; To -40 Degrees F/ -40 Degrees C, Freeze Protection
12849	BLOCK HEATER, ENGINE 120V/1000W, for Cummins ISB/B6.7/ISL/L9 Engines
	<u>Includes</u> : BLOCK HEATER SOCKET Receptacle Type; Mounted below Drivers Door
12EYX	ENGINE, DIESEL {Cummins L9 330} EPA 2024, 330HP @ 2200 RPM, 1000 lb-ft Torque @ 1200 RPM, 2200 RPM Governed Speed, 330 Peak HP (Max)
12THT	FAN DRIVE {Horton Drivemaster} Two-Speed Type, Direct Drive, with Residual Torque Device for Disengaged Fan Speed
	<u>Includes</u> : FAN Nylon
12UWZ	RADIATOR Aluminum, Cross Flow, Front to Back System, 1228 SqIn, with 1167 SqIn Charge Air Cooler, Includes In-Tank Oil Cooler
	<u>Includes</u> : DEAERATION SYSTEM with Surge Tank : HOSE CLAMPS, RADIATOR HOSES Gates Shrink Band Type; Thermoplastic Coolant Hose Clamps : RADIATOR HOSES Premium, Rubber
12VAG	AIR CLEANER Single Element, with Integral Snow Valve and In-Cab Control
12VKC	EMISSION, CALENDAR YEAR {Cummins L9} EPA, OBD and GHG Certified for Calendar Year 2025
12VXT	THROTTLE, HAND CONTROL Engine Speed Control; Electronic, Stationary, Variable Speed; Mounted on Steering Wheel
12VYL	ACCESSORY WIRING, SPECIAL for Road Speed Wire Coiled Under Instrument Panel for Customer Use
12VYP	ENGINE CONTROL, REMOTE MOUNTED No Provision for Remote Mounted Engine Control
12WCG	HOSE CLAMPS, RADIATOR HOSES {R.G. Ray Mini Flex Seal} Coil Spring/"T"-Bolt Constant Torque Type, for Radiator Hoses over 1" I.D.
12WVH	EPA IDLE COMPLIANCE Low NOx Idle Engine, Complies with EPA Clean Air Regulations; Includes "Certified Clean Idle" Decal on Door
12WZE	CARB IDLE COMPLIANCE Does Not Comply with California Clean Air Idle Regulations
12XCS	CARB EMISSION WARR COMPLIANCE Does Not Comply with CARB Emission Warranty
13BDR	TRANSMISSION, AUTOMATIC {Allison 3500 RDS} 6th Generation Controls, Wide Ratio, 6-Speed with Double Overdrive, with PTO Provision, Less Retarder, Includes Oil Level Sensor, with 80,000-lb GVW and GCW Max, On/Off Highway

Code	Description
13WET	TRANSMISSION SHIFT CONTROL Column Mounted Stalk Shifter, Not for Use with Allison 1000 & 2000 Series Transmission
13WLP	TRANSMISSION OIL Synthetic; 29 thru 42 Pints
13WUC	ALLISON SPARE INPUT/OUTPUT for Rugged Duty Series (RDS) and Regional Haul Series (RHS), General Purpose Trucks, Construction, Package Number 223
13WVV	NEUTRAL AT STOP Allison Transmission Shifts to Neutral When Service Brake is Depressed and Vehicle is at Stop; Remains in Neutral Until Service Brake is Released
13WYH	TRANSMISSION TCM LOCATION Located Inside Cab
13WYU	SHIFT CONTROL PARAMETERS {Allison} 3000 or 4000 Series Transmissions, Performance Programming
13XAM	PTO LOCATION Dual, Customer Intends to Install PTO at Left and/or Right Side of Transmission
14899	SUSPENSION AIR CONTROL VALVE Pressure Release Control In Cab
14ARB	AXLE, REAR, SINGLE {Meritor RS-23-160} Single Reduction, 23,000-lb Capacity, Driver Controlled Locking Differential, 200 Wheel Ends . Gear Ratio: 6.14
14TBZ	SUSPENSION, REAR, AIR, SINGLE {Hendrickson PRIMAAX EX} 23,000-lb Capacity, 9.0" Ride Height, with Shock Absorbers
14WMG	AXLE, REAR, LUBE {EmGard FE-75W-90} Synthetic Oil; 30 thru 39.99 Pints
15924	FUEL TANK STRAPS Bright Finish Stainless Steel
15LNS	FUEL/WATER SEPARATOR {Racor 400 Series} 12 VDC Electric Heater, Includes Pre-Heater, with Primer Pump, Includes Water-in-Fuel Sensor, Mounted on Engine
15SGG	FUEL TANK Top Draw, Non-Polished Aluminum, D-Style, 19" Tank Depth, 70 US Gal (265L), Mounted Left Side, Under Cab
15WDG	DEF TANK 7 US Gal (26L) Capacity, Frame Mounted Outside Left Rail, Under Cab
16030	CAB Conventional, Day Cab
16BAM	AIR CONDITIONER with Integral Heater and Defroster
16GED	GAUGE CLUSTER Base Level; English with English Electronic Speedometer <u>Includes</u> : GAUGE CLUSTER DISPLAY: Base Level (3" Monochromatic Display), Premium Level (5" LCD Color Display); Odometer, Voltmeter, Diagnostic Messages, Gear Indicator, Trip Odometer, Total Engine Hours, Trip Hours, MPG, Distance to Empty/Refill for : GAUGE CLUSTER Speedometer, Tachometer, Engine Coolant Temp, Fuel Gauge, DEF Gauge, Oil Pressure Gauge, Primary and Secondary Air Pressure : WARNING SYSTEM Low Fuel, Low DEF, Low Oil Pressure, High Engine Coolant Temp, Low Battery Voltage (Visual and Audible), Low Air Pressure (Primary and Secondary)
16HGH	GAUGE, OIL TEMP, AUTO TRANS for Allison Transmission
16HHE	GAUGE, AIR CLEANER RESTRICTION {Filter-Minder} Mounted in Instrument Panel
16HKT	IP CLUSTER DISPLAY On Board Diagnostics Display of Fault Codes in Gauge Cluster
16KZX	SEAT, DRIVER {National 2000 195} Air Suspension, High Back with Integral Headrest, Cloth, Isolator, 8" Adjuster, 1 Chamber Lumbar, 2 Position Front Cushion Adjust, 6-23 Degree Back Angle Adjust
16SEE	GRAB HANDLE, EXTERIOR Chrome, Towel Bar Type, with Anti-Slip Rubber Inserts, for Cab Entry Mounted Left Side at B-Pillar
16SJX	MIRROR, CONVEX, HOOD MOUNTED {Lang Mekra} (2) Right and Left Sides, Bright, Heated, 7.5" Sq.

Code	Description
16SMX	SEAT, PASSENGER {Seats, Inc.} Non Suspension, High Back, Fixed Back, Integral Headrest, Cloth, for use with Batteries in Cab
16SNR	MIRRORS (2) C-Loop, Power Adjust, Heated, LED Clearance Lights, Bright Heads and Arms, 7.5" x 14" Flat Glass, Includes 7.5" x 7" Convex Mirrors, for 102" Load Width <u>Notes</u> : Mirror Dimensions are Rounded to the Nearest 0.5"
16VKK	CAB INTERIOR TRIM Diamond, for Day Cab <u>Includes</u> : CONSOLE, OVERHEAD Molded Plastic with Dual Storage Pockets, Retainer Nets and CB Radio Pocket; Located Above Driver and Passenger : DOME LIGHT, CAB Door Activated and Push On-Off at Light Lens, Timed Theater Dimming, Reading Lights; Integral to Overhead Console, Center Mounted : SUN VISOR (3) Padded Vinyl; 2 Moveable (Front-to-Side) Primary Visors, Driver Side with Vanity Mirror and Toll Ticket Strap, plus 1 Auxiliary Visor (Front Only), Driver Side
16VLV	MONITOR, TIRE PRESSURE Omit
16VSL	WINDSHIELD Heated, Single Piece
16WBY	ARM REST, RIGHT, DRIVER SEAT
16WHJ	HOSE CLAMPS, HEATER HOSE {Breeze} Belleville Washer Type
16WJU	WINDOW, POWER (2) and Power Door Locks, Left and Right Doors, Includes Express Down Feature
16WLS	FRESH AIR FILTER Attached to Air Intake Cover on Cowl Tray in Front of Windshield Under Hood
16WSK	CAB REAR SUSPENSION Air Bag Type
16XJP	INSTRUMENT PANEL Wing Panel
16XWD	SUNSHADE, EXTERIOR Aerodynamic, Painted Roof Color, with Integral Clearance/Marker Lights
16ZJA	ACCESS, CAB Aluminum, Self-Cleaning, Open and Serrated Design, Driver & Passenger Sides, Two Steps per Door, for use with Day Cab, Extended Cab or Sleeper Cab
27DUR	WHEELS, FRONT {Accuride 41730} DISC; 22.5x9.00 Rims, Standard Polish Aluminum, 10-Stud, 285.75mm BC, Hub-Piloted, Flanged Nut, with Steel Hubs
28DWR	WHEELS, REAR {Accuride 43644} DUAL DISC; 22.5x8.25 Rims, Standard Polish Aluminum, 10-Stud, 285.75mm BC, Hub-Piloted, Flanged Nut, with Steel Hubs
29WLK	WHEEL BEARING, FRONT, LUBE {EmGard FE-75W-90} Synthetic Oil
7382135430	(4) TIRE, REAR 11R22.5 Load Range H HDW2 (CONTINENTAL), 495 rev/mile, 75 MPH, Drive
7792545437	(2) TIRE, FRONT 315/80R22.5 Load Range L HAU 3 WT (CONTINENTAL), 480 rev/mile, 68 MPH, All-Position

Services Section:

40128	WARRANTY Standard for HV507, HV50B, HV607 Models, Effective with Vehicles Built July 1, 2017 or Later, CTS-2025A Detail Floor Mats MTE Dual Air Bags Heated Wiper Blades
-------	--

Code

Description

40XCC SRV CONTRACT, EXT ELECTRICAL {Navistar Prepackaged Components} Excludes Starter and Alternator, To 60-Month/50,000 Miles (80,000 km)

SS Oil Pan

<u>Description</u>	(US DOLLAR)	<u>Price</u>
Net Sales Price:		\$122,367.00

Please feel free to contact me regarding these specifications should your interests or needs change. I am confident you will be pleased with the quality and service of an International vehicle.

This proposal was written using 2025 Sourcewell pricing. The final price may vary depending on production date, additional surcharges and/or freight increases. Your representative will reach out to you if there are any additional changes.

Navistar International Sourcewell Contract #060920-NVS

Approved by Seller:

Accepted by Purchaser:

Official Title and Date

Firm or Business Name

Authorized Signature

Authorized Signature and Date

This proposal is not binding upon the seller without Seller's Authorized Signature

Official Title and Date

The TOPS FET calculation is an estimate for reference purposes only. The seller or retailer is responsible for calculating and reporting/paying appropriate FET to the IRS.

The limited warranties applicable to the vehicles described herein are Navistar, Inc.'s standard printed warranties which are incorporated herein by reference and to which you have been provided a copy and hereby agree to their terms and conditions.



HV507 SFA

Sales Proposal For:
Village of Mukwonago

Presented By:
LAKESIDE INTL, LLC

Prepared For:

Village of Mukwonago
 Ron Bittner
 440 Rivercrest Ct.
 Mukwonago, WI 53149-1759
 (262)363 - 6420
 Reference ID: SW 100CA

Presented By:

LAKESIDE INTL, LLC
 Patrick McNamara
 11000 W SILVER SPRING RD
 MILWAUKEE WI 53225 -
 (414)353-4800

Thank you for the opportunity to provide you with the following quotation on a new International truck. I am sure the following detailed specification will meet your operational requirements, and I look forward to serving your business needs.

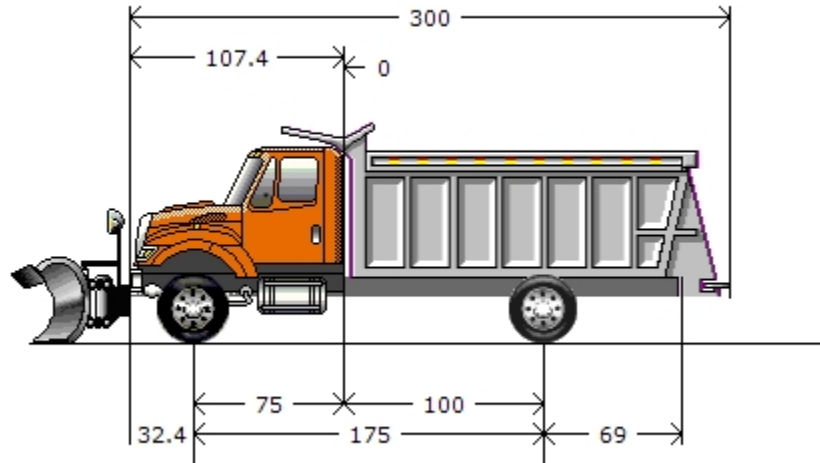

Model Profile
2026 HV507 SFA (HV507)

AXLE CONFIG:	4X2
APPLICATION:	Front Plow and Wing with Spreader
MISSION:	Requested GVWR: 43000. Calc. GVWR: 43000. Calc. GCWR: 80000 Calc. Start / Grade Ability: 37.44% / 2.95% @ 55 MPH Calc. Geared Speed: 66.8 MPH
DIMENSION:	Wheelbase: 175.00, CA: 100.00, Axle to Frame: 69.00
ENGINE, DIESEL:	{Cummins L9 330} EPA 2024, 330HP @ 2200 RPM, 1000 lb-ft Torque @ 1200 RPM, 2200 RPM Governed Speed, 330 Peak HP (Max)
TRANSMISSION, AUTOMATIC:	{Allison 3500 RDS} 6th Generation Controls, Wide Ratio, 6-Speed with Double Overdrive, with PTO Provision, Less Retarder, Includes Oil Level Sensor, with 80,000-lb GVW and GCW Max, On/Off Highway
CLUTCH:	Omit Item (Clutch & Control)
AXLE, FRONT NON-DRIVING:	{Meritor MFS-20-133A} Wide Track, I-Beam Type, 20,000-lb Capacity
AXLE, REAR, SINGLE:	{Meritor RS-23-160} Single Reduction, 23,000-lb Capacity, Driver Controlled Locking Differential, 200 Wheel Ends Gear Ratio: 6.14
CAB:	Conventional, Day Cab
TIRE, FRONT:	(2) 315/80R22.5 Load Range L HAU 3 WT (CONTINENTAL), 480 rev/mile, 68 MPH, All-Position
TIRE, REAR:	(4) 11R22.5 Load Range H HDW2 (CONTINENTAL), 495 rev/mile, 75 MPH, Drive
SUSPENSION, REAR, AIR, SINGLE:	{Hendrickson PRIMAAX EX} 23,000-lb Capacity, 9.0" Ride Height, with Shock Absorbers
PAINT:	Cab schematic 100WK Location 1: 0311, Omaha Orange (Std) Chassis schematic N/A

Code	Description
HV50700	Base Chassis, Model HV507 SFA with 175.00 Wheelbase, 100.00 CA, and 69.00 Axle to Frame.
1570	TOW HOOK, FRONT (2) Frame Mounted
1ANA	AXLE CONFIGURATION 4x2
	<u>Notes</u> : Pricing may change if axle configuration is changed.
1CAJ	FRAME RAILS Heat Treated Alloy Steel (120,000 PSI Yield); 10.866" x 3.622" x 0.437" (276.0mm x 92.0mm x 11.1mm); 456.0" (11582mm) Maximum OAL
1LLA	BUMPER, FRONT Swept Back, Steel, Heavy Duty
1WDS	FRAME EXTENSION, FRONT Integral; 20" In Front of Grille
1WEV	WHEELBASE RANGE 146" (370cm) Through and Including 195" (495cm)
1WRN	BRACKET, CAB MOUNT Heavy Duty
2ARY	AXLE, FRONT NON-DRIVING {Meritor MFS-20-133A} Wide Track, I-Beam Type, 20,000-lb Capacity
3AHU	SUSPENSION, FRONT, SPRING Multi-Stage Parabolic Taper Leaf, Shackle Type, 20,000-lb Capacity, with Shock Absorbers
4091	BRAKE SYSTEM, AIR Dual System for Straight Truck Applications <u>Includes</u> : BRAKE LINES Color and Size Coded Nylon : DRAIN VALVE Twist-Type : GAUGE, AIR PRESSURE (2) Air 1 and Air 2 Gauges; Located in Instrument Cluster : PARKING BRAKE CONTROL Yellow Knob, Located on Instrument Panel : PARKING BRAKE VALVE For Truck : QUICK RELEASE VALVE On Rear Axle for Spring Brake Release: 1 for 4x2, 2 for 6x4 : SPRING BRAKE MODULATOR VALVE R-7 for 4x2, SR-7 with relay valve for 6x4/8x6
4619	TRAILER CONNECTIONS Four-Wheel, with Hand Control Valve and Tractor Protection Valve, for Straight Truck <u>Notes</u> : When electronic stability control is ordered with trailer connections on a 4x2 truck, please check the operator manual for trailer weight restrictions.
4732	DRAIN VALVE {Berg} with Pull Chain, for Air Tank
4AZA	AIR BRAKE ABS {Bendix AntiLock Brake System} 4-Channel (4 Sensor/4 Modulator) Full Vehicle Wheel Control System
4EBT	AIR DRYER {Bendix AD-IP} with Heater
4EXU	BRAKE CHAMBERS, REAR AXLE {Bendix EverSure} 30/30 SqIn Spring Brake
4EXV	BRAKE CHAMBERS, FRONT AXLE {Bendix} 24 SqIn
4GBM	BRAKE, PARKING Manual Push-Pull Pneumatic Parking Brake
4LAA	SLACK ADJUSTERS, FRONT {Haldex} Automatic
4LGA	SLACK ADJUSTERS, REAR {Haldex} Automatic
4SPA	AIR COMPRESSOR {Cummins} 18.7 CFM
4VKC	AIR DRYER LOCATION Mounted Inside Left Rail, Back of Cab
4WBX	DUST SHIELDS, FRONT BRAKE for Air Cam Brakes
4WDM	DUST SHIELDS, REAR BRAKE for Air Cam Brakes

Code	Description
4WZJ	AIR TANK LOCATION (2) : One Mounted Under Each Rail, Front of Rear Suspension, Parallel to Rail
4XDR	BRAKES, REAR {Meritor 16.5X7 Q-PLUS CAST} Air S-Cam Type, Cast Spider, Fabricated Shoe, Double Anchor Pin, Size 16.5" X 7", 23,000-lb Capacity per Axle
4XDT	BRAKES, FRONT {Meritor 16.5X6 Q-PLUS CAST} Air S-Cam Type, Cast Spider, Fabricated Shoe, Double Anchor Pin, Size 16.5" X 6", 23,000-lb Capacity
5710	STEERING COLUMN Tilting and Telescoping
5CAW	STEERING WHEEL 4-Spoke; 18" Dia., Black
5PTB	STEERING GEAR (2) {Sheppard M100/M80} Dual Power
6DGG	DRIVELINE SYSTEM {Dana Spicer} 1710, for 4x2/6x2
7BES	AFTERTREATMENT COVER Polished Aluminum
7BLW	EXHAUST SYSTEM Horizontal Aftertreatment System, Frame Mounted Right Side Under Cab, for Single Vertical Tail Pipe, Frame Mounted Right Side Back of Cab
7WBA	TAIL PIPE (1) Turnback Type, Bright
7WBS	MUFFLER/TAIL PIPE GUARD (1) Bright Stainless Steel
7WCM	EXHAUST HEIGHT 8' 10"
8000	ELECTRICAL SYSTEM 12-Volt, Standard Equipment
	<u>Includes</u>
	: DATA LINK CONNECTOR For Vehicle Programming and Diagnostics In Cab
	: HAZARD SWITCH Push On/Push Off, Located on Instrument Panel to Right of Steering Wheel
	: HEADLIGHT DIMMER SWITCH Integral with Turn Signal Lever
	: PARKING LIGHT Integral with Front Turn Signal and Rear Tail Light
	: STARTER SWITCH Electric, Key Operated
	: STOP, TURN, TAIL & B/U LIGHTS Dual, Rear, Combination with Reflector
	: TURN SIGNAL SWITCH Self-Cancelling for Trucks, Manual Cancelling for Tractors, with Lane Change Feature
	: WINDSHIELD WIPER SWITCH 2-Speed with Wash and Intermittent Feature (5 Pre-Set Delays), Integral with Turn Signal Lever
	: WINDSHIELD WIPERS Single Motor, Electric, Cowl Mounted
	: WIRING, CHASSIS Color Coded and Continuously Numbered
8695	SNOW SHIELD (2) Chrome; for Dual Air Horns
8899	JUMP START STUD (2) 12V, Remote Mounted
8GXD	ALTERNATOR {Leece-Neville AV1160P2013} Brush Type, 12 Volt, 160 Amp Capacity, Pad Mount, with Remote Sense
8HAB	BODY BUILDER WIRING Back of Day Cab at Left Frame or Under Sleeper, Extended or Crew Cab at Left Frame; Includes Sealed Connectors for Tail/Amber Turn/Marker/ Backup/Accessory Power/Ground and Sealed Connector for Stop/Turn
8HAH	ELECTRIC TRAILER BRAKE/LIGHTS Accommodation Package to Rear of Frame; for Combined Trailer Stop, Tail, Turn, Marker Light Circuits; Includes Electric Trailer Brake Accommodation Package with Cab Connections for Mounting Customer Installed Electric Brake Unit, Less Trailer Socket
8HXT	HORN, AIR (2) Single Tone, Chrome, Roof Mounted, with Lanyard Pull Cord
8MMZ	BATTERY SYSTEM {Fleetrite AGM-GP31} Maintenance-Free, (3) AGM 12-Volt 2475CCA Total, Top Threaded Stud
8RGA	2-WAY RADIO Wiring Effects; Wiring with 20 Amp Fuse Protection, Includes Ignition Wire with 5 Amp Fuse, Wire Ends Heat Shrink and Routed to Center of Header Console in Cab

Code	Description
8RMZ	SPEAKERS (2) 6.5" Dual Cone Mounted in Both Doors, (2) 5.25" Dual Cone Mounted in Both B-Pillars
8RPP	ANTENNA Shark Fin, Roof Mounted
8RPS	RADIO AM/FM/WB/Clock/Bluetooth/USB Input/Auxiliary Input
8THB	BACK-UP ALARM Electric, 102 dBA
8THJ	AUXILIARY HARNESS 3.0' for Auxiliary Front Head Lights and Turn Signals for Front Plow Applications
8TKK	TRAILER AUXILIARY FEED CIRCUIT for Electric Trailer Brake Accommodation/Air Trailer ABS; with 30 Amp Fuse and Relay, Controlled by Ignition Switch
8VAY	HORN, ELECTRIC Disc Style
8WGL	WINDSHIELD WIPER SPD CONTROL Force Wipers to Slowest Intermittent Speed When Park Brake Set and Wipers Left on for a Predetermined Time
8WPH	CLEARANCE/MARKER LIGHTS (5) {Truck Lite} Amber LED Lights, Flush Mounted on Cab or Sunshade
8WPZ	TEST EXTERIOR LIGHTS Pre-Trip Inspection will Cycle all Exterior Lamps Except Back-up Lights
8WRB	HEADLIGHTS ON W/WIPERS Headlights Will Automatically Turn On if Windshield Wipers are Turned On
8WTK	STARTING MOTOR {Delco Remy 38MT Type 300} 12 Volt, Less Thermal Over-Crank Protection
8WWJ	INDICATOR, LOW COOLANT LEVEL with Audible Alarm
8WXD	ALARM, PARKING BRAKE Electric Horn Sounds in Repetitive Manner When Vehicle Park Brake is "NOT" Set, with Ignition "OFF" and any Door Opened
8XAH	CIRCUIT BREAKERS Manual-Reset (Main Panel) SAE Type III with Trip Indicators, Replaces All Fuses
8XDZ	BATTERY BOX Steel, 2-3 Battery Capacity, Mounted Inside the Cab, Under Passenger Seat
8XGT	TURN SIGNALS, FRONT Includes LED Side Turn Lights Mounted on Fender
8XNY	HEADLIGHTS Halogen
8XPK	POWER SOURCE, ADDITIONAL Auxiliary Power Outlet (APO) with USB-A Port and USB-C Port, Located in the Instrument Panel
9585	FENDER EXTENSIONS Rubber
9AAB	LOGOS EXTERIOR Model Badges
9AAE	LOGOS EXTERIOR, ENGINE Badges
9ANG	HOOD, HATCH (01) for Servicing
9HAN	INSULATION, UNDER HOOD for Sound Abatement
9HBM	GRILLE Stationary, Chrome
9HBN	INSULATION, SPLASH PANELS for Sound Abatement
9WBC	FRONT END Tilting, Fiberglass, with Three Piece Construction, for WorkStar/HV
10021	CHASSIS COATING Corrosion Resistant E-Coat Primer Coating for Single Frame Rails
10060	PAINT SCHEMATIC, PT-1 Single Color, Design 100
	<u>Includes</u> : PAINT SCHEMATIC ID LETTERS "WK"
10761	PAINT TYPE Base Coat/Clear Coat, 1-2 Tone
10AGB	COMMUNICATIONS MODULE Telematics Device with Over the Air Programming; Includes Five Year Data Plan and International 360

Code	Description
10JPA	CUSTOMER IDENTITY for Sourcewell
10SLV	PROMOTIONAL PACKAGE Government Silver Package
10UAV	VEHICLE REGISTRATION IDENTITY ID for Non-CARB Omnibus and/or Non-ACT Adopting State or Exempt Vehicle. Not for use on vehicles registering in CA/MA /OR/NJ/NY/WA. Contains non-mitigated legacy engine & cannot be registered in CA unless exempt. You may be held liable under state law for failure to properly register vehicle.
	<u>Notes</u> : CANNOT BE REGISTERED IN CA. For vehicles that will be registered in States other than CA.
10WBS	KEYS - ALL ALIKE, ADDITIONAL 2 Keys
10WKN	KEYS - ALL ALIKE, ID I-1624 Compatible with Z-250
11001	CLUTCH Omit Item (Clutch & Control)
12703	ANTI-FREEZE Red, Extended Life Coolant; To -40 Degrees F/ -40 Degrees C, Freeze Protection
12849	BLOCK HEATER, ENGINE 120V/1000W, for Cummins ISB/B6.7/ISL/L9 Engines
	<u>Includes</u> : BLOCK HEATER SOCKET Receptacle Type; Mounted below Drivers Door
12EYX	ENGINE, DIESEL {Cummins L9 330} EPA 2024, 330HP @ 2200 RPM, 1000 lb-ft Torque @ 1200 RPM, 2200 RPM Governed Speed, 330 Peak HP (Max)
12THT	FAN DRIVE {Horton Drivemaster} Two-Speed Type, Direct Drive, with Residual Torque Device for Disengaged Fan Speed
	<u>Includes</u> : FAN Nylon
12UWZ	RADIATOR Aluminum, Cross Flow, Front to Back System, 1228 SqIn, with 1167 SqIn Charge Air Cooler, Includes In-Tank Oil Cooler
	<u>Includes</u> : DEAERATION SYSTEM with Surge Tank : HOSE CLAMPS, RADIATOR HOSES Gates Shrink Band Type; Thermoplastic Coolant Hose Clamps : RADIATOR HOSES Premium, Rubber
12VAG	AIR CLEANER Single Element, with Integral Snow Valve and In-Cab Control
12VKC	EMISSION, CALENDAR YEAR {Cummins L9} EPA, OBD and GHG Certified for Calendar Year 2025
12VXT	THROTTLE, HAND CONTROL Engine Speed Control; Electronic, Stationary, Variable Speed; Mounted on Steering Wheel
12VYL	ACCESSORY WIRING, SPECIAL for Road Speed Wire Coiled Under Instrument Panel for Customer Use
12VYP	ENGINE CONTROL, REMOTE MOUNTED No Provision for Remote Mounted Engine Control
12WCG	HOSE CLAMPS, RADIATOR HOSES {R.G. Ray Mini Flex Seal} Coil Spring/"T"-Bolt Constant Torque Type, for Radiator Hoses over 1" I.D.
12WVH	EPA IDLE COMPLIANCE Low NOx Idle Engine, Complies with EPA Clean Air Regulations; Includes "Certified Clean Idle" Decal on Door
12WZE	CARB IDLE COMPLIANCE Does Not Comply with California Clean Air Idle Regulations
12XCS	CARB EMISSION WARR COMPLIANCE Does Not Comply with CARB Emission Warranty
13BDR	TRANSMISSION, AUTOMATIC {Allison 3500 RDS} 6th Generation Controls, Wide Ratio, 6-Speed with Double Overdrive, with PTO Provision, Less Retarder, Includes Oil Level Sensor, with 80,000-lb GVW and GCW Max, On/Off Highway

Code	Description
13WET	TRANSMISSION SHIFT CONTROL Column Mounted Stalk Shifter, Not for Use with Allison 1000 & 2000 Series Transmission
13WLP	TRANSMISSION OIL Synthetic; 29 thru 42 Pints
13WUC	ALLISON SPARE INPUT/OUTPUT for Rugged Duty Series (RDS) and Regional Haul Series (RHS), General Purpose Trucks, Construction, Package Number 223
13WVV	NEUTRAL AT STOP Allison Transmission Shifts to Neutral When Service Brake is Depressed and Vehicle is at Stop; Remains in Neutral Until Service Brake is Released
13WYH	TRANSMISSION TCM LOCATION Located Inside Cab
13WYU	SHIFT CONTROL PARAMETERS {Allison} 3000 or 4000 Series Transmissions, Performance Programming
13XAM	PTO LOCATION Dual, Customer Intends to Install PTO at Left and/or Right Side of Transmission
14899	SUSPENSION AIR CONTROL VALVE Pressure Release Control In Cab
14ARB	AXLE, REAR, SINGLE {Meritor RS-23-160} Single Reduction, 23,000-lb Capacity, Driver Controlled Locking Differential, 200 Wheel Ends . Gear Ratio: 6.14
14TBZ	SUSPENSION, REAR, AIR, SINGLE {Hendrickson PRIMAAX EX} 23,000-lb Capacity, 9.0" Ride Height, with Shock Absorbers
14WMG	AXLE, REAR, LUBE {EmGard FE-75W-90} Synthetic Oil; 30 thru 39.99 Pints
15924	FUEL TANK STRAPS Bright Finish Stainless Steel
15LNS	FUEL/WATER SEPARATOR {Racor 400 Series} 12 VDC Electric Heater, Includes Pre-Heater, with Primer Pump, Includes Water-in-Fuel Sensor, Mounted on Engine
15SGG	FUEL TANK Top Draw, Non-Polished Aluminum, D-Style, 19" Tank Depth, 70 US Gal (265L), Mounted Left Side, Under Cab
15WDG	DEF TANK 7 US Gal (26L) Capacity, Frame Mounted Outside Left Rail, Under Cab
16030	CAB Conventional, Day Cab
16BAM	AIR CONDITIONER with Integral Heater and Defroster
16GED	GAUGE CLUSTER Base Level; English with English Electronic Speedometer <u>Includes</u> : GAUGE CLUSTER DISPLAY: Base Level (3" Monochromatic Display), Premium Level (5" LCD Color Display); Odometer, Voltmeter, Diagnostic Messages, Gear Indicator, Trip Odometer, Total Engine Hours, Trip Hours, MPG, Distance to Empty/Refill for : GAUGE CLUSTER Speedometer, Tachometer, Engine Coolant Temp, Fuel Gauge, DEF Gauge, Oil Pressure Gauge, Primary and Secondary Air Pressure : WARNING SYSTEM Low Fuel, Low DEF, Low Oil Pressure, High Engine Coolant Temp, Low Battery Voltage (Visual and Audible), Low Air Pressure (Primary and Secondary)
16HGH	GAUGE, OIL TEMP, AUTO TRANS for Allison Transmission
16HHE	GAUGE, AIR CLEANER RESTRICTION {Filter-Minder} Mounted in Instrument Panel
16HKT	IP CLUSTER DISPLAY On Board Diagnostics Display of Fault Codes in Gauge Cluster
16KZX	SEAT, DRIVER {National 2000 195} Air Suspension, High Back with Integral Headrest, Cloth, Isolator, 8" Adjuster, 1 Chamber Lumbar, 2 Position Front Cushion Adjust, 6-23 Degree Back Angle Adjust
16SEE	GRAB HANDLE, EXTERIOR Chrome, Towel Bar Type, with Anti-Slip Rubber Inserts, for Cab Entry Mounted Left Side at B-Pillar
16SJX	MIRROR, CONVEX, HOOD MOUNTED {Lang Mekra} (2) Right and Left Sides, Bright, Heated, 7.5" Sq.

Code	Description
16SMX	SEAT, PASSENGER {Seats, Inc.} Non Suspension, High Back, Fixed Back, Integral Headrest, Cloth, for use with Batteries in Cab
16SNR	MIRRORS (2) C-Loop, Power Adjust, Heated, LED Clearance Lights, Bright Heads and Arms, 7.5" x 14" Flat Glass, Includes 7.5" x 7" Convex Mirrors, for 102" Load Width <u>Notes</u> : Mirror Dimensions are Rounded to the Nearest 0.5"
16VKK	CAB INTERIOR TRIM Diamond, for Day Cab <u>Includes</u> : CONSOLE, OVERHEAD Molded Plastic with Dual Storage Pockets, Retainer Nets and CB Radio Pocket; Located Above Driver and Passenger : DOME LIGHT, CAB Door Activated and Push On-Off at Light Lens, Timed Theater Dimming, Reading Lights; Integral to Overhead Console, Center Mounted : SUN VISOR (3) Padded Vinyl; 2 Moveable (Front-to-Side) Primary Visors, Driver Side with Vanity Mirror and Toll Ticket Strap, plus 1 Auxiliary Visor (Front Only), Driver Side
16VLV	MONITOR, TIRE PRESSURE Omit
16VSL	WINDSHIELD Heated, Single Piece
16WBY	ARM REST, RIGHT, DRIVER SEAT
16WHJ	HOSE CLAMPS, HEATER HOSE {Breeze} Belleville Washer Type
16WJU	WINDOW, POWER (2) and Power Door Locks, Left and Right Doors, Includes Express Down Feature
16WLS	FRESH AIR FILTER Attached to Air Intake Cover on Cowl Tray in Front of Windshield Under Hood
16WSK	CAB REAR SUSPENSION Air Bag Type
16XJP	INSTRUMENT PANEL Wing Panel
16XWD	SUNSHADE, EXTERIOR Aerodynamic, Painted Roof Color, with Integral Clearance/Marker Lights
16ZJA	ACCESS, CAB Aluminum, Self-Cleaning, Open and Serrated Design, Driver & Passenger Sides, Two Steps per Door, for use with Day Cab, Extended Cab or Sleeper Cab
27DUR	WHEELS, FRONT {Accuride 41730} DISC; 22.5x9.00 Rims, Standard Polish Aluminum, 10-Stud, 285.75mm BC, Hub-Piloted, Flanged Nut, with Steel Hubs
28DWR	WHEELS, REAR {Accuride 43644} DUAL DISC; 22.5x8.25 Rims, Standard Polish Aluminum, 10-Stud, 285.75mm BC, Hub-Piloted, Flanged Nut, with Steel Hubs
29WLK	WHEEL BEARING, FRONT, LUBE {EmGard FE-75W-90} Synthetic Oil
7382135430	(4) TIRE, REAR 11R22.5 Load Range H HDW2 (CONTINENTAL), 495 rev/mile, 75 MPH, Drive
7792545437	(2) TIRE, FRONT 315/80R22.5 Load Range L HAU 3 WT (CONTINENTAL), 480 rev/mile, 68 MPH, All-Position

Services Section:

40128	WARRANTY Standard for HV507, HV50B, HV607 Models, Effective with Vehicles Built July 1, 2017 or Later, CTS-2025A Detail Floor Mats MTE Dual Air Bags Heated Wiper Blades
-------	--

Code

Description

40XCC SRV CONTRACT, EXT ELECTRICAL {Navistar Prepackaged Components} Excludes Starter and Alternator, To 60-Month/50,000 Miles (80,000 km)

SS Oil Pan

<u>Description</u>	(US DOLLAR)	<u>Price</u>
Net Sales Price:		\$122,367.00

Please feel free to contact me regarding these specifications should your interests or needs change. I am confident you will be pleased with the quality and service of an International vehicle.

This proposal was written using 2025 Sourcewell pricing. The final price may vary depending on production date, additional surcharges and/or freight increases. Your representative will reach out to you if there are any additional changes.

Navistar International Sourcewell Contract #060920-NVS

Approved by Seller:

Accepted by Purchaser:

Official Title and Date

Firm or Business Name

Authorized Signature

Authorized Signature and Date

This proposal is not binding upon the seller without Seller's Authorized Signature

Official Title and Date

The TOPS FET calculation is an estimate for reference purposes only. The seller or retailer is responsible for calculating and reporting/paying appropriate FET to the IRS.

The limited warranties applicable to the vehicles described herein are Navistar, Inc.'s standard printed warranties which are incorporated herein by reference and to which you have been provided a copy and hereby agree to their terms and conditions.

Accounts Payable Cover Sheet

Report:	Period or corresponding disbursement date		
Village Accounts Payable	4/2/2025	\$	168,310.99
Court	3/3/2025	\$	100.00
Payroll	3/4/2025	\$	170.00
WE Energies	3/4/2025	\$	55,769.19
Court	3/6/2025	\$	8,373.51
Spectrum	3/12/2025	\$	1,025.92
Payroll	3/12/2025	\$	2,023.28
Payroll	3/12/2025	\$	9,180.39
Library AP	3/14/2025	\$	15,234.77
Town of Mukwonago - Fire Settlement	3/21/2025	\$	309,974.29
Envirotech Equipment (Vac Truck)	3/21/2025	\$	622,173.00
Payroll	3/26/2025	\$	5,763.06
US Bank Credit Card	3/26/2025	\$	12,492.67
Payroll	3/26/2025	\$	196,703.73
		\$	-
		\$	-
		\$	-
Total for Approval:		\$	<u>1,407,294.80</u>

The preceding list of bills payable was approved for payment

Date: _____

Approved by: _____

Reconciliation to Check Register for Prior Month

3/6/2025 COW - Approved	\$	557,643.21
3/20/2025 Board - Approved	\$	397,170.74
Total	\$	<u>954,813.95</u>
Prior Month activity listed above	\$	<u>1,238,983.81</u>
Total Disbursements	\$	2,193,797.76
Check Register Balance		<u>2,193,797.76</u>
Difference	\$	<u><u>-</u></u>

INVOICE NUMBER	DESCRIPTION	DISTRIBUTIONS\AMOUNTS	AMOUNT	APPROVAL DEPARTMENT	POST DATE
VENDOR NAME: AC SERVICE INC					
CU25-42384	VILLAGE HALL COMMUNITY ROOM AC DOWN PAYM480-5700-573000	13,097.50	13,097.50	DPW	04/03/2025
TOTAL VENDOR AC SERVICE INC			13,097.50		
VENDOR NAME: ALSCO					
IMIL2105402	VILLAGE HA; WALK OFF MATS	100-5160-521900	50.60	DPW	04/03/2025
IMIL2103433	PD MAT CLEANING	100-5211-539400	38.00	POLICE	04/03/2025
TOTAL VENDOR ALSCO			88.60		
VENDOR NAME: AMAZON CAPITOL SERVICES					
19Y6-1NCM-LYG7	GIFT BAGS, BINDER DIVIDERS, STICKERS, CA	100-5142-531100	222.88	CLERK	04/03/2025
		100-5144-531100	9.41		
		100-5111-531100	49.40		
1VHK-XDWR-6V6T	DRILL BITS	100-5323-531100	59.89	DPW	04/03/2025
TOTAL VENDOR AMAZON CAPITOL SERVICES			341.58		
VENDOR NAME: AMIRA HOFMANN					
2025 CLOTHING	2025 CLOTHING ALLOWANCE - HOFFMAN	150-5222-534600	105.00	FIRE	04/03/2025
TOTAL VENDOR AMIRA HOFMANN			105.00		
VENDOR NAME: AT & T					
4655989908	AT&T 911 FIBER LINE	100-5211-522900	976.96	POLICE	04/03/2025
TOTAL VENDOR AT & T			976.96		
VENDOR NAME: BOUND TREE MEDICAL LLC					
85700812	EMS SUPPLIES	150-5231-531100	24.79	FIRE	04/03/2025
TOTAL VENDOR BOUND TREE MEDICAL LLC			24.79		
VENDOR NAME: BUREAU OF CORRECTIONAL ENTERPR					
922-000550	PARK SIGNS	100-5521-531100	565.10	DPW	04/03/2025
922-00551	PARK ASIGN	100-5521-531100	282.55	DPW	04/03/2025
TOTAL VENDOR BUREAU OF CORRECTIONAL ENTERPR			847.65		
VENDOR NAME: C & M AUTO PARTS INC					
6079-394750	SQUAD OIL FILTERS	100-5212-539500	21.95	POLICE	04/03/2025
6079-394703	TIGER ROADSIDE MOWER AIR FILTERS	100-5324-539500	156.48	DPW	04/03/2025
6079-394715	TIGER ROADSIDE MOWER BELTS	100-5324-539500	43.26	DPW	04/03/2025
6079-394632	SHOP SUPPLIES	100-5323-531100	11.72	DPW	04/03/2025
6079-394631	2017 AMBULANCE CREDIT	150-5231-539500	(28.72)	FIRE	04/03/2025
6079-394480	2017 AMBULANCE REPAIR	150-5231-539500	209.57	FIRE	04/03/2025
6079-394486	2017 AMBULANCE REPAIR	150-5231-539500	522.52	FIRE	04/03/2025
TOTAL VENDOR C & M AUTO PARTS INC			936.78		
VENDOR NAME: CARLSON RACINE ROOFING & SHEET					
33309	FIRE STATION #1 ROOF REPAIRS	100-5220-539400	1,678.00	DPW	04/03/2025
TOTAL VENDOR CARLSON RACINE ROOFING & SHEET			1,678.00		
VENDOR NAME: CINTAS					
4224148775	STAFF UNIFORMS AND SHOP SUPPLIES	100-5323-531100	135.42	DPW	04/03/2025

INVOICE NUMBER	DESCRIPTION	DISTRIBUTIONS\AMOUNTS	AMOUNT	APPROVAL DEPARTMENT	POST DATE
VENDOR NAME: CINTAS					
4224148835	UNIFORM SERVICE	610-6920-693000 66.44 620-8400-856000 66.43	132.87	UTILITIES	04/03/2025
4224879170	UNIFORM SERVICE	610-6920-693000 75.06 620-8400-856000 75.06	150.12	UTILITIES	04/03/2025
4224879157	STAFF UNIFORMS AND SHOP SUPPLIES	100-5323-531100 135.42	135.42	DPW	04/03/2025
TOTAL VENDOR CINTAS			<u>553.83</u>		
VENDOR NAME: CJ & ASSOCIATES, INC					
0234358-IN	FLOOR REPAIR AT THE RBM	100-5512-582100 699.98	699.98	DPW	04/03/2025
TOTAL VENDOR CJ & ASSOCIATES, INC			<u>699.98</u>		
VENDOR NAME: CORE & MAIN LP					
W570139	METERS	610-0000-134600 9,135.00	9,135.00	UTILITIES	04/03/2025
TOTAL VENDOR CORE & MAIN LP			<u>9,135.00</u>		
VENDOR NAME: COREY OIL, LTD					
589175 FIRE	OIL INVOICE	150-5222-531100 137.25 150-5231-531100 137.02	274.27	FIRE	04/03/2025
589175 PD	SQUAD MOTOR OIL	100-5212-535100 274.27	274.27	POLICE	04/03/2025
589175 DPW	MOTOR OIL, GREESE AND CHAINSAW OIL	100-5611-531100 62.80 100-5324-539500 90.11 100-5324-535100 301.26	454.17	DPW	04/03/2025
TOTAL VENDOR COREY OIL, LTD			<u>1,002.71</u>		
VENDOR NAME: DF TOMASINI, INC.					
DFT#2326-31	CURB BOX REPAIR - 318 N. ROCHESTER	610-6452-665200 309.63	309.63	UTILITIES	04/03/2025
TOTAL VENDOR DF TOMASINI, INC.			<u>309.63</u>		
VENDOR NAME: ENVIRONMENT CONTROL					
36642-613	VILAGE HALL CLEANING SERVICES	100-5160-521900 748.00	748.00	DPW	04/03/2025
TOTAL VENDOR ENVIRONMENT CONTROL			<u>748.00</u>		
VENDOR NAME: EXCEL BUILDING SERVICES LLC					
4397	PD BUILDING CLEANING SERVICE	100-5211-539400 975.00	975.00	POLICE	04/03/2025
TOTAL VENDOR EXCEL BUILDING SERVICES LLC			<u>975.00</u>		
VENDOR NAME: GENERAL FIRE EQUIPMENT CO					
INV153203	B34 CRADLE POINT AND CAMERA INSTALL	150-5222-539500 900.00	900.00	FIRE	04/03/2025
TOTAL VENDOR GENERAL FIRE EQUIPMENT CO			<u>900.00</u>		
VENDOR NAME: GORDON FLESCH CO					

INVOICE NUMBER	DESCRIPTION	DISTRIBUTIONS\AMOUNTS	AMOUNT	APPROVAL DEPARTMENT	POST DATE
VENDOR NAME: GORDON FLESCH CO					
IN15091141	CANON COPIER FEBRUARY 2025 COPIES	100-5142-531200	21.13	169.16 ALLOCATE	04/03/2025
		100-5300-539900	19.91		
		100-5120-531100	8.42		
		100-5141-531100	5.24		
		100-5145-531100	9.85		
		100-5241-531200	3.94		
		100-5632-531200	4.86		
		100-5211-531200	20.77		
		150-5221-531100	20.98		
		410-5363-531200	1.69		
		440-5511-531200	19.28		
		500-5344-531200	2.35		
		610-6902-690300	16.29		
		620-8400-851000	14.45		
TOTAL VENDOR GORDON FLESCH CO				<u>169.16</u>	
VENDOR NAME: HAWKINS WATER TREATMENT					
7012900	CHEMICALS FOR WATER TREATMENT	610-6300-663100	50.00	50.00 UTILITIES	04/03/2025
TOTAL VENDOR HAWKINS WATER TREATMENT				<u>50.00</u>	
VENDOR NAME: HINCKLEY SPRINGS					
23853226 031525	VH AND DPW DRINKING WATER	100-5160-531100	22.85	57.14 DPW	04/03/2025
		100-5323-531100	34.29		
TOTAL VENDOR HINCKLEY SPRINGS				<u>57.14</u>	
VENDOR NAME: HIPPENMEYER, REILLY, BLUM,					
57369	PROSECUTIONS	100-5130-521900	990.00	990.00 FINANCE	04/03/2025
TOTAL VENDOR HIPPENMEYER, REILLY, BLUM,				<u>990.00</u>	
VENDOR NAME: HOME DEPOT					
FEB 2025	MISC SIUPPLIES FOR DPW AND PARKS	100-5323-531100	466.15	731.42 DPW	04/03/2025
		100-5521-531100	265.27		
FEB 2025 PD	REPAIR SUPPLIES	100-5211-539500	79.00	79.00 POLICE	04/03/2025
FB 2025 FD	FIRE REPAIR	150-5222-539500	6.47	6.47 FIRE	04/03/2025
TOTAL VENDOR HOME DEPOT				<u>816.89</u>	
VENDOR NAME: HORN OIL					

INVOICE NUMBER	DESCRIPTION	DISTRIBUTIONS\AMOUNTS	AMOUNT	APPROVAL DEPARTMENT	POST DATE
VENDOR NAME: HORN OIL					
1546295	MONTHLY FUEL	100-5212-535100	2,347.67	8,767.18	ALLOCATE 04/03/2025
		100-5241-535100	91.77		
		100-5324-535100	3,816.20		
		150-5222-535100	418.40		
		150-5231-535100	849.25		
		610-6920-693300	93.40		
		620-8010-828000	632.05		
		620-8010-825500	37.64		
		620-8010-821300	480.80		
TOTAL VENDOR HORN OIL				8,767.18	
VENDOR NAME: JACKSON-HIRSCH					
1095916	EMS SUPPLIES	150-5231-531100	63.97	63.97	FIRE 04/03/2025
TOTAL VENDOR JACKSON-HIRSCH				63.97	
VENDOR NAME: JAMES IMAGING SYSTEMS					
1546295	QUARTERLY COPIER FEES	100-5211-531200	142.40	142.40	POLICE 04/03/2025
TOTAL VENDOR JAMES IMAGING SYSTEMS				142.40	
VENDOR NAME: JAMES IMAGING SYSTEMS, INC					
38821572	COPIER INVOICE	150-5221-531100	156.79	156.79	FIRE 04/03/2025
38599120	COPIER INVOICE	150-5221-531100	226.37	226.37	FIRE 04/03/2025
TOTAL VENDOR JAMES IMAGING SYSTEMS, INC				383.16	
VENDOR NAME: LANGE ENTERPRISES INC					
90562	CARDINAL RIDGE SUBDIVISION STREET SIGNS	100-5348-531100	189.77	189.77	DPW 04/03/2025
TOTAL VENDOR LANGE ENTERPRISES INC				189.77	
VENDOR NAME: LIFE-ASSIST, INC.					
1580364	EMS SUPPLIES	150-5231-531100	965.76	965.76	FIRE 04/03/2025
1581963	EMS SUPPLIES	150-5231-531100	695.80	695.80	FIRE 04/03/2025
TOTAL VENDOR LIFE-ASSIST, INC.				1,661.56	
VENDOR NAME: MACQUEEN EQUIPMENT					
P37666	STREET SWEEPER REPAIR PARTS	100-5345-539500	361.11	361.11	DPW 04/03/2025
P3724	SWEEPER REPAIR PARTS	100-5345-539500	202.69	202.69	DPW 04/03/2025
TOTAL VENDOR MACQUEEN EQUIPMENT				563.80	
VENDOR NAME: MUKWONAGO AREA CHAMBER OF COMM					
FEB 2025	FEB '25 945 GREENWALD CT	100-0000-244000	1,426.16	1,426.16	CLERK 04/03/2025
SPRING FLING 2025	SPRING FLING ANNUAL SPONSORSHIP	100-5111-539900	500.00	500.00	ADMIN 04/03/2025
TOTAL VENDOR MUKWONAGO AREA CHAMBER OF COMM				1,926.16	
VENDOR NAME: MUN ENVIRON GRP WASTEWATER DIV					
2025 MEMBERSHIP	LEGAL COUNSEL- REGULATORY	620-8400-852000	900.90	900.90	UTILITIES 04/03/2025
TOTAL VENDOR MUN ENVIRON GRP WASTEWATER DIV				900.90	
VENDOR NAME: MUNICIPAL LAW & LITIGATION					
14284	GFLP 20CV1292; 22AP284	100-5130-521900	1,720.00	1,720.00	FINANCE 04/03/2025

INVOICE NUMBER	DESCRIPTION	DISTRIBUTIONS\AMOUNTS	AMOUNT	APPROVAL DEPARTMENT	POST DATE
VENDOR NAME: MUNICIPAL LAW & LITIGATION					
TOTAL VENDOR MUNICIPAL LAW & LITIGATION			1,720.00		
VENDOR NAME: NAPA AUTO PARTS - SP018					
243965	OIL FOR WELL MOTORS	610-6210-662300	79.99	UTILITIES	04/03/2025
TOTAL VENDOR NAPA AUTO PARTS - SP018			79.99		
VENDOR NAME: NORTHERN LAKE SERVICE INC					
2503717	COMPLIANCE SAMPLING- COURIER SERVICE	610-6300-663200	62.00	UTILITIES	04/03/2025
2504338	COMPLIANCE SAMPLING- BACTI	610-6300-663200	145.00	UTILITIES	04/03/2025
TOTAL VENDOR NORTHERN LAKE SERVICE INC			207.00		
VENDOR NAME: PUBLIC SERVICE COMMISSION OF WI					
2502-I-03980	PSC DIRECT ASSESSMENT	610-6920-692800	732.55	UTILITIES	04/03/2025
TOTAL VENDOR PUBLIC SERVICE COMMISSION OF WI			732.55		
VENDOR NAME: QUILL LLC					
43208185	OFFICE SUPPLIES	100-5211-531100	19.97	POLICE	04/03/2025
TOTAL VENDOR QUILL LLC			19.97		
VENDOR NAME: RUEKERT & MIELKE, INC.					
156016	12-00000.100 General Services	100-5335-521900	3,079.25	FINANCE	04/03/2025
		100-5670-521900	7,016.00		
		500-5344-521900	262.50		
		500-5344-521900	14.36		
		100-5660-521900	157.14		
156017	12-00000.400 Sewer Utility Services	620-8400-852000	596.75	FINANCE	04/03/2025
156018	12-10096.300 Deback Drive Infrastructure	200-5335-521900	17,380.02	FINANCE	04/03/2025
156025	12-10135.630 ESRI Licenses	100-5335-521900	416.66	FINANCE	04/03/2025
		610-6920-692300	416.67		
		620-8400-852000	416.67		
156030	12-10063/2025 Annual GIS Services	610-6920-692300	1,388.00	FINANCE	04/03/2025
		620-8400-852000	1,388.00		
156037	12-10167.100 WWTF Biosolids Handling & S	620-8400-852000	1,500.00	FINANCE	04/03/2025
156038	12-10169.200 Wells 3 and 4 Radium Remova	610-0000-000109	16,503.40	FINANCE	04/03/2025
156035	12-10204.200 Police Station Garage Addit	480-5700-573000	14,562.20	FINANCE	04/03/2025
156024	12-10205.100A Sewer and Water Comprehens	610-6920-692300	246.00	FINANCE	04/03/2025
		620-8400-852000	4,293.75		
156029	12-10215.125 Village Planning Services	100-5632-521900	6,540.80	FINANCE	04/03/2025
156028	12-10229.320 Milwaukee Tool 2024 Parking	100-0000-211400	164.44	FINANCE	04/03/2025
156034	12-10232.200 Field Park Pickleball Court	480-5700-584900	13,655.05	FINANCE	04/03/2025
156033	12-10233.240 Village Fiber Route Sanitar	620-8400-852000	4,768.50	FINANCE	04/03/2025
156019	12-10149.310 EDGEWOOD CONDOS / EROSION C	100-0000-211425	365.32	FINANCE	04/03/2025
156020	12-10185.300 GS GLOBAL EXPANSION / EROSI	100-0000-211425	168.88	FINANCE	04/03/2025
156026	12-10191.100 EDGEWOOD CONDOS BIELINSKI D	100-0000-211425	196.44	FINANCE	04/03/2025
156022	12-10196.300 ADELHELM LUBRICAT EXPANSIO	100-0000-211425	164.44	FINANCE	04/03/2025

INVOICE NUMBER	DESCRIPTION	DISTRIBUTIONS\AMOUNTS	AMOUNT	APPROVAL DEPARTMENT	POST DATE
VENDOR NAME: RUEKERT & MIELKE, INC.					
156023	12-10210.300 CARDINAL RIDGE HEIN DEVELOP	100-0000-211425	597.63	597.63 FINANCE	04/03/2025
156027	12-10216.310 AZURA SENIOR LIVING / EROSI	100-0000-211425	292.44	292.44 FINANCE	04/03/2025
15603	12-10230.150 ST. JAMES CHURCH EXPANSION	100-0000-211425	97.50	97.50 FINANCE	04/03/2025
156036	12-10234.150 BROOKLIFE CHURCH EXPANSION	100-0000-211425	1,369.25	1,369.25 FINANCE	04/03/2025
TOTAL VENDOR RUEKERT & MIELKE, INC.			98,018.06		
VENDOR NAME: SCAN GROUP					
250517	COURT ENVELOPES	100-5120-531100	354.00	354.00 FINANCE	04/03/2025
TOTAL VENDOR SCAN GROUP			354.00		
VENDOR NAME: SHERWIN-WILLIAMS					
5604-2	PAINT SUPPLIES- BLOWER BUILDING	620-8010-827000	158.30	158.30 UTILITIES	04/03/2025
5023-3	PAINT SUPPLIES- BLOWER BUILDING	620-8010-827000	1,908.01	1,908.01 UTILITIES	04/03/2025
TOTAL VENDOR SHERWIN-WILLIAMS			2,066.31		
VENDOR NAME: SHI INTERNATIONAL CORP					
B19273599	FIBER PROJECT	350-5700-576400	1,434.58	1,434.58 FINANCE	04/03/2025
TOTAL VENDOR SHI INTERNATIONAL CORP			1,434.58		
VENDOR NAME: STATE CHEMICAL SOLUTIONS					
903694058	SHOP SUPPLIES VARIOUS CHEMICAL ARESOL CA	100-5323-531100	342.99	342.99 DPW	04/03/2025
TOTAL VENDOR STATE CHEMICAL SOLUTIONS			342.99		
VENDOR NAME: STERICYCLE					
8010196637	SHREDDING SERVICES	100-5141-531100	52.05	104.11 ALLOCATE	04/03/2025
		100-5142-531100	26.03		
		100-5632-531100	26.03		
TOTAL VENDOR STERICYCLE			104.11		
VENDOR NAME: USA BLUEBOOK					
INV00652532	DEWATERING BAG	610-6452-665200	31.95	31.95 UTILITIES	04/03/2025
TOTAL VENDOR USA BLUEBOOK			31.95		
VENDOR NAME: VERIZON WIRELESS					
6108397427	CELL SERVICE	610-6920-692100	107.81	215.62 UTILITIES	04/03/2025
		620-8400-851000	107.81		
TOTAL VENDOR VERIZON WIRELESS			215.62		
VENDOR NAME: VILLAGE OF MUKWONAGO					

INVOICE NUMBER	DESCRIPTION	DISTRIBUTIONS\AMOUNTS	AMOUNT	APPROVAL DEPARTMENT	POST DATE
VENDOR NAME: VILLAGE OF MUKWONAGO					
2025 Q1 UTILITY	2025 MARCH QUARTERLY UTILITY BILLS	100-5521-522100	207.80	10,232.76 ALLOCATE	04/03/2025
		610-6300-663200	137.94		
		100-5521-522100	112.32		
		100-5160-522100	719.90		
		610-6300-663200	233.42		
		150-5221-522100	758.33		
		610-6300-663200	207.80		
		100-5521-522100	382.75		
		440-5511-522100	724.76		
		100-5512-522100	125.13		
		100-5521-522100	207.80		
		610-6300-663200	207.80		
		100-5323-522100	1,445.70		
		100-5211-522100	591.80		
		100-5521-522100	125.13		
		620-8010-827000	3,615.97		
		610-6300-663200	220.61		
		100-5521-522100	207.80		
TOTAL VENDOR VILLAGE OF MUKWONAGO				<u>10,232.76</u>	
VENDOR NAME: WAUKESHA CTY TREASURER					
2025-10040021	WAUKESHA COUNTY PUBLIC EDUCATION AND OUT	500-5344-535200	256.00	3,048.00 DPW	04/03/2025
		100-5660-521900	2,792.00		
TOTAL VENDOR WAUKESHA CTY TREASURER				<u>3,048.00</u>	
VENDOR NAME: WI ECONOMIC DEVELOPMENT CORP					
INV-007777	CONNECT COMMUNITIES ANNUAL FEE	100-5632-532400	200.00	200.00 ADMIN	04/03/2025
TOTAL VENDOR WI ECONOMIC DEVELOPMENT CORP				<u>200.00</u>	
VENDOR NAME: WI EMS ASSOCIATION					
NV00004700	2025 WEMSA MEMBERSHIP DUES	150-5221-532400	400.00	400.00 FIRE	04/03/2025
TOTAL VENDOR WI EMS ASSOCIATION				<u>400.00</u>	
GRAND TOTAL:				168,310.99	

Post Date	Journal	Description	GL Number	DR Amount	CR Amount
03/03/2025	AP	WI MUNICIPAL JUDGES ASSOCIATION	Invoice: 2025 DUES Ref#: 69360 (2025 DUES ADD'L AMOUNT)		
AP Trx #: 104871		MEMBERSHIP DUES	100-5120-532400	100.00	
		Vnd: 3158 Invoice: 2025 DUES	100-0000-211000		100.00
		Expected Check Run: 03/03/2025			
				100.00	100.00
				100.00	100.00
Cash/Payable Account Totals:		VOUCHERS PAYABLE	100-0000-211000		100.00
			GRAND TOTAL:		100.00

Post Date	Journal	Description	GL Number	DR Amount	CR Amount
03/04/2025	AP	INVOICE CLOUD	Invoice: 1743-2025_2 Ref#: 69447(INVOICE CLOUD MONTHLY FEES - FEB 2025)		
AP Trx #: 104873		INVOICE CLOUD CC FEES MR	100-5142-539900	3.13	
		INVOICE CLOUD CC FEES BUILDING	100-5241-539900	46.88	
		INVOICE CLOUD CC FEES UTILITIES	410-5363-539900	35.00	
		INVOICE CLOUD CC FEES UTILITIES	610-6920-692100	49.99	
		INVOICE CLOUD CC FEES UTILITIES	620-8300-840000	35.00	
		Vnd: 2921 Invoice: 1743-2025_2	100-0000-211000		50.01
		Vnd: 2921 Invoice: 1743-2025_2	410-0000-211000		35.00
		Vnd: 2921 Invoice: 1743-2025_2	610-0000-211000		49.99
		Vnd: 2921 Invoice: 1743-2025_2	620-0000-211000		35.00
		Expected Check Run: 03/04/2025			
				170.00	170.00
				170.00	170.00
Cash/Payable Account Totals:					
		VOUCHERS PAYABLE	100-0000-211000		50.01
		VOUCHERS PAYABLE	410-0000-211000		35.00
		VOUCHERS PAYABLE	610-0000-211000		49.99
		VOUCHERS PAYABLE	620-0000-211000		35.00
		GRAND TOTAL:			170.00

Post Date	Journal	Description	GL Number	DR Amount	CR Amount
03/21/2025	AP	WE ENERGIES	Invoice: 5384441096 Ref#: 69361(0700126680-00001 Digester Gas)		
AP Trx #: 104875		0700126680-00001 Digester Gas	620-8010-821200	913.78	
		Vnd: 0034 Invoice: 5384441096	620-0000-211000		913.78
		Expected Check Run: 03/04/2025		<u>913.78</u>	<u>913.78</u>
03/21/2025	AP	WE ENERGIES	Invoice: 5384441096 Ref#: 69362(0700126680-00002 Well #3 Elec)		
AP Trx #: 104876		0700126680-00002 Well #3 Elec	610-6200-662200	1,715.34	
		Vnd: 0034 Invoice: 5384441096	610-0000-211000		1,715.34
		Expected Check Run: 03/04/2025		<u>1,715.34</u>	<u>1,715.34</u>
03/21/2025	AP	WE ENERGIES	Invoice: 5384441096 Ref#: 69363(0700126680-00003 Street Lights)		
AP Trx #: 104877		0700126680-00003 Street Lights	100-5342-522200	3,733.10	
		Vnd: 0034 Invoice: 5384441096	100-0000-211000		3,733.10
		Expected Check Run: 03/04/2025		<u>3,733.10</u>	<u>3,733.10</u>
03/21/2025	AP	WE ENERGIES	Invoice: 5384441096 Ref#: 69364(0700126680-00004 Greenwald)		
AP Trx #: 104878		0700126680-00004 Greenwald	610-6200-662200	329.02	
		Vnd: 0034 Invoice: 5384441096	610-0000-211000		329.02
		Expected Check Run: 03/04/2025		<u>329.02</u>	<u>329.02</u>
03/21/2025	AP	WE ENERGIES	Invoice: 5384441096 Ref#: 69365(0700126680-00005 Booster Station)		
AP Trx #: 104879		0700126680-00005 Booster Station	610-6200-662200	949.96	
		Vnd: 0034 Invoice: 5384441096	610-0000-211000		949.96
		Expected Check Run: 03/04/2025		<u>949.96</u>	<u>949.96</u>
03/21/2025	AP	WE ENERGIES	Invoice: 5384441096 Ref#: 69366(0700126680-00006 Field Park)		
AP Trx #: 104880		0700126680-00006 Field Park	100-5521-522200	73.84	
		Vnd: 0034 Invoice: 5384441096	100-0000-211000		73.84
		Expected Check Run: 03/04/2025		<u>73.84</u>	<u>73.84</u>

Post Date	Journal	Description	GL Number	DR Amount	CR Amount
03/21/2025	AP	WE ENERGIES	Invoice: 5384441096 Ref#: 69367(0700126680-00007 1240 N. Rochester)		
AP Trx #: 104881		0700126680-00007 1240 N. Rochester	620-8020-821000	157.59	
		Vnd: 0034 Invoice: 5384441096	620-0000-211000		157.59
		Expected Check Run: 03/04/2025		<u>157.59</u>	<u>157.59</u>
03/21/2025	AP	WE ENERGIES	Invoice: 5384441096 Ref#: 69368(0700126680-00008 Police Garage)		
AP Trx #: 104882		0700126680-00008 Police Garage	100-5211-522200	209.23	
		Vnd: 0034 Invoice: 5384441096	100-0000-211000		209.23
		Expected Check Run: 03/04/2025		<u>209.23</u>	<u>209.23</u>
03/21/2025	AP	WE ENERGIES	Invoice: 5384441096 Ref#: 69369(0700126680-00009 Fld Prk Baseball Lights)		
AP Trx #: 104883		0700126680-00009 Fld Prk Baseball Lights	100-5521-522200	21.61	
		Vnd: 0034 Invoice: 5384441096	100-0000-211000		21.61
		Expected Check Run: 03/04/2025		<u>21.61</u>	<u>21.61</u>
03/21/2025	AP	WE ENERGIES	Invoice: 5384441096 Ref#: 69370(0700126680-000010 Fox River View)		
AP Trx #: 104884		0700126680-000010 Fox River View	620-8020-821000	252.68	
		Vnd: 0034 Invoice: 5384441096	620-0000-211000		252.68
		Expected Check Run: 03/04/2025		<u>252.68</u>	<u>252.68</u>
03/21/2025	AP	WE ENERGIES	Invoice: 5384441096 Ref#: 69371(0700126680-000011 DPW Elec)		
AP Trx #: 104885		0700126680-000011 DPW Elec	100-5323-522200	666.39	
		Vnd: 0034 Invoice: 5384441096	100-0000-211000		666.39
		Expected Check Run: 03/04/2025		<u>666.39</u>	<u>666.39</u>
03/21/2025	AP	WE ENERGIES	Invoice: 5384441096 Ref#: 69372(0700126680-000012 Fire)		
AP Trx #: 104886		0700126680-000012 Fire	150-5221-522200	2,922.92	
		Vnd: 0034 Invoice: 5384441096	150-0000-211000		2,922.92
		Expected Check Run: 03/04/2025		<u>2,922.92</u>	<u>2,922.92</u>

Post Date	Journal	Description	GL Number	DR Amount	CR Amount
03/21/2025	AP	WE ENERGIES	Invoice: 5384441096 Ref#: 69373(0700126680-000013 police-CTH E N of Sugd		
AP Trx #: 104887		0700126680-000013 police-CTH E N of Sugd	100-5211-522200	19.90	
		Vnd: 0034 Invoice: 5384441096	100-0000-211000		19.90
		Expected Check Run: 03/04/2025		<u>19.90</u>	<u>19.90</u>
03/21/2025	AP	WE ENERGIES	Invoice: 5384441096 Ref#: 69374(0700126680-000014 Hall)		
AP Trx #: 104888		0700126680-000014 Hall	100-5160-522200	1,387.80	
		Vnd: 0034 Invoice: 5384441096	100-0000-211000		1,387.80
		Expected Check Run: 03/04/2025		<u>1,387.80</u>	<u>1,387.80</u>
03/21/2025	AP	WE ENERGIES	Invoice: 5384441096 Ref#: 69375(0700126680-000014 Hall Gas)		
AP Trx #: 104889		0700126680-000014 Hall Gas	100-5160-522400	575.48	
		Vnd: 0034 Invoice: 5384441096	100-0000-211000		575.48
		Expected Check Run: 03/04/2025		<u>575.48</u>	<u>575.48</u>
03/21/2025	AP	WE ENERGIES	Invoice: 5384441096 Ref#: 69376(0700126680-000016 Miniwauken Park)		
AP Trx #: 104890		0700126680-000016 Miniwauken Park	100-5521-522200	39.70	
		Vnd: 0034 Invoice: 5384441096	100-0000-211000		39.70
		Expected Check Run: 03/04/2025		<u>39.70</u>	<u>39.70</u>
03/21/2025	AP	WE ENERGIES	Invoice: 5384441096 Ref#: 69377(0700126680-000017 Holz Elec)		
AP Trx #: 104891		0700126680-000017 Holz Elec	620-8010-821100	10,290.77	
		Vnd: 0034 Invoice: 5384441096	620-0000-211000		10,290.77
		Expected Check Run: 03/04/2025		<u>10,290.77</u>	<u>10,290.77</u>
03/21/2025	AP	WE ENERGIES	Invoice: 5384441096 Ref#: 69378(0700126680-000018 Parks)		
AP Trx #: 104892		0700126680-000018 Parks	100-5521-522200	19.37	
		Vnd: 0034 Invoice: 5384441096	100-0000-211000		19.37
		Expected Check Run: 03/04/2025		<u>19.37</u>	<u>19.37</u>

Post Date	Journal	Description	GL Number	DR Amount	CR Amount
03/21/2025	AP	WE ENERGIES	Invoice: 5384441096 Ref#: 69379(0700126680-000019 Atkinson Pump)		
AP Trx #: 104893		0700126680-000019 Atkinson Pump	620-8020-821000	499.77	
		Vnd: 0034 Invoice: 5384441096	620-0000-211000		499.77
		Expected Check Run: 03/04/2025		<u>499.77</u>	<u>499.77</u>
03/21/2025	AP	WE ENERGIES	Invoice: 5384441096 Ref#: 69380(0700126680-000020 Well #6)		
AP Trx #: 104894		0700126680-000020 Well #6	610-6200-662200	1,452.63	
		Vnd: 0034 Invoice: 5384441096	610-0000-211000		1,452.63
		Expected Check Run: 03/04/2025		<u>1,452.63</u>	<u>1,452.63</u>
03/21/2025	AP	WE ENERGIES	Invoice: 5384441096 Ref#: 69381(0700126680-000021 DPW Gas)		
AP Trx #: 104895		0700126680-000021 DPW Gas	100-5323-522400	904.26	
		Vnd: 0034 Invoice: 5384441096	100-0000-211000		904.26
		Expected Check Run: 03/04/2025		<u>904.26</u>	<u>904.26</u>
03/21/2025	AP	WE ENERGIES	Invoice: 5384441096 Ref#: 69382(0700126680-000022 Concession Building)		
AP Trx #: 104896		0700126680-000022 Concession Building	100-5521-522200	89.26	
		Vnd: 0034 Invoice: 5384441096	100-0000-211000		89.26
		Expected Check Run: 03/04/2025		<u>89.26</u>	<u>89.26</u>
03/21/2025	AP	WE ENERGIES	Invoice: 5384441096 Ref#: 69383(0700126680-000023 Well #3 Gas)		
AP Trx #: 104897		0700126680-000023 Well #3 Gas	610-6200-662200	9.57	
		Vnd: 0034 Invoice: 5384441096	610-0000-211000		9.57
		Expected Check Run: 03/04/2025		<u>9.57</u>	<u>9.57</u>
03/21/2025	AP	WE ENERGIES	Invoice: 5384441096 Ref#: 69384(0700126680-000024 Parks-200 S Rochester)		
AP Trx #: 104898		0700126680-000024 Parks-200 S Rochester	100-5342-522200	24.71	
		Vnd: 0034 Invoice: 5384441096	100-0000-211000		24.71
		Expected Check Run: 03/04/2025		<u>24.71</u>	<u>24.71</u>

Post Date	Journal	Description	GL Number	DR Amount	CR Amount
03/21/2025	AP	WE ENERGIES	Invoice: 5384441096 Ref#: 69385(0700126680-000025 Tower)		
AP Trx #: 104899		0700126680-000025 Tower	610-6200-662200	27.99	
		Vnd: 0034 Invoice: 5384441096	610-0000-211000		27.99
		Expected Check Run: 03/04/2025		<u>27.99</u>	<u>27.99</u>
03/21/2025	AP	WE ENERGIES	Invoice: 5384441096 Ref#: 69386(0700126680-000027 Police)		
AP Trx #: 104900		0700126680-000027 Police	100-5211-522200	2,426.51	
		Vnd: 0034 Invoice: 5384441096	100-0000-211000		2,426.51
		Expected Check Run: 03/04/2025		<u>2,426.51</u>	<u>2,426.51</u>
03/21/2025	AP	WE ENERGIES	Invoice: 5384441096 Ref#: 69387(0700126680-000028 Miniwaukan Pavilion)		
AP Trx #: 104901		0700126680-000028 Miniwaukan Pavilion	100-5521-522200	24.37	
		Vnd: 0034 Invoice: 5384441096	100-0000-211000		24.37
		Expected Check Run: 03/04/2025		<u>24.37</u>	<u>24.37</u>
03/21/2025	AP	WE ENERGIES	Invoice: 5384441096 Ref#: 69388(0700126680-000029 F. Park Sump Pump)		
AP Trx #: 104902		0700126680-000029 F. Park Sump Pump	100-5521-522200	20.24	
		Vnd: 0034 Invoice: 5384441096	100-0000-211000		20.24
		Expected Check Run: 03/04/2025		<u>20.24</u>	<u>20.24</u>
03/21/2025	AP	WE ENERGIES	Invoice: 5384441096 Ref#: 69389(0700126680-000030 Andrews Street)		
AP Trx #: 104903		0700126680-000030 Andrews Street	100-5521-522200	119.50	
		Vnd: 0034 Invoice: 5384441096	100-0000-211000		119.50
		Expected Check Run: 03/04/2025		<u>119.50</u>	<u>119.50</u>
03/21/2025	AP	WE ENERGIES	Invoice: 5384441096 Ref#: 69390(0700126680-000031 Holz Gas)		
AP Trx #: 104904		0700126680-000031 Holz Gas	620-8010-821200	516.94	
		Vnd: 0034 Invoice: 5384441096	620-0000-211000		516.94
		Expected Check Run: 03/04/2025		<u>516.94</u>	<u>516.94</u>

Post Date	Journal	Description	GL Number	DR Amount	CR Amount
03/21/2025	AP	WE ENERGIES	Invoice: 5384441096 Ref#: 69391(0700126680-000032 Well #4 Elec)		
AP Trx #: 104905		0700126680-000032 Well #4 Elec	610-6200-662200	3,915.46	
		Vnd: 0034 Invoice: 5384441096	610-0000-211000		3,915.46
		Expected Check Run: 03/04/2025		<u>3,915.46</u>	<u>3,915.46</u>
03/21/2025	AP	WE ENERGIES	Invoice: 5384441096 Ref#: 69392(0700126680-000033 Parks)		
AP Trx #: 104906		0700126680-000033 Parks	100-5521-522200	29.53	
		Vnd: 0034 Invoice: 5384441096	100-0000-211000		29.53
		Expected Check Run: 03/04/2025		<u>29.53</u>	<u>29.53</u>
03/21/2025	AP	WE ENERGIES	Invoice: 5384441096 Ref#: 69393(0700126680-000034 Street Lights)		
AP Trx #: 104907		0700126680-000034 Street Lights	100-5342-522200	80.82	
		Vnd: 0034 Invoice: 5384441096	100-0000-211000		80.82
		Expected Check Run: 03/04/2025		<u>80.82</u>	<u>80.82</u>
03/21/2025	AP	WE ENERGIES	Invoice: 5384441096 Ref#: 69394(0700126680-000036 Flashers)		
AP Trx #: 104908		0700126680-000036 Flashers	100-5211-522200	11.20	
		Vnd: 0034 Invoice: 5384441096	100-0000-211000		11.20
		Expected Check Run: 03/04/2025		<u>11.20</u>	<u>11.20</u>
03/21/2025	AP	WE ENERGIES	Invoice: 5384441096 Ref#: 69395(0700126680-000037 Well #4 Gas)		
AP Trx #: 104909		0700126680-000037 Well #4 Gas	610-6200-662200	124.06	
		Vnd: 0034 Invoice: 5384441096	610-0000-211000		124.06
		Expected Check Run: 03/04/2025		<u>124.06</u>	<u>124.06</u>
03/21/2025	AP	WE ENERGIES	Invoice: 5384441096 Ref#: 69396(0700126680-000038 Museum)		
AP Trx #: 104910		0700126680-000038 Museum	100-5512-522200	452.94	
		Vnd: 0034 Invoice: 5384441096	100-0000-211000		452.94
		Expected Check Run: 03/04/2025		<u>452.94</u>	<u>452.94</u>

Post Date	Journal	Description	GL Number	DR Amount	CR Amount
03/21/2025	AP	WE ENERGIES	Invoice: 5384441096 Ref#: 69397(0700126680-000039 Well #5)		
AP Trx #: 104911		0700126680-000039 Well #5	610-6200-662200	2,856.27	
		Vnd: 0034 Invoice: 5384441096	610-0000-211000		2,856.27
		Expected Check Run: 03/04/2025		<u>2,856.27</u>	<u>2,856.27</u>
03/21/2025	AP	WE ENERGIES	Invoice: 5384441096 Ref#: 69398(0700126680-00043 Outdoor Stage)		
AP Trx #: 104912		0700126680-00043 Outdoor Stage	100-5521-522200	43.30	
		Vnd: 0034 Invoice: 5384441096	100-0000-211000		43.30
		Expected Check Run: 03/04/2025		<u>43.30</u>	<u>43.30</u>
03/21/2025	AP	WE ENERGIES	Invoice: 5384441096 Ref#: 69399(0700126680-00048 Miniwauken Park)		
AP Trx #: 104913		0700126680-00048 Miniwauken Park	100-5521-522200	18.00	
		Vnd: 0034 Invoice: 5384441096	100-0000-211000		18.00
		Expected Check Run: 03/04/2025		<u>18.00</u>	<u>18.00</u>
03/21/2025	AP	WE ENERGIES	Invoice: 5384441096 Ref#: 69400(0709449777-00001 Library Gas)		
AP Trx #: 104914		0709449777-00001 Library Gas	440-5511-522400	3,611.17	
		Vnd: 0034 Invoice: 5384441096	440-0000-211000		3,611.17
		Expected Check Run: 03/04/2025		<u>3,611.17</u>	<u>3,611.17</u>
03/21/2025	AP	WE ENERGIES	Invoice: 5384441096 Ref#: 69401(0709449777-00002 Library Elec)		
AP Trx #: 104915		0709449777-00002 Library Elec	440-5511-522200	2,359.97	
		Vnd: 0034 Invoice: 5384441096	440-0000-211000		2,359.97
		Expected Check Run: 03/04/2025		<u>2,359.97</u>	<u>2,359.97</u>
03/21/2025	AP	WE ENERGIES	Invoice: 5384441096 Ref#: 69402(0712697628-00001 Tower Radio Bldg)		
AP Trx #: 104916		0712697628-00001 Tower Radio Bldg	100-5211-522200	29.71	
		Vnd: 0034 Invoice: 5384441096	100-0000-211000		29.71
		Expected Check Run: 03/04/2025		<u>29.71</u>	<u>29.71</u>

Post Date	Journal	Description	GL Number	DR Amount	CR Amount
03/21/2025	AP	WE ENERGIES	Invoice: 5384441096 Ref#: 69403(0712697628-00002 Mukw Dam)		
AP Trx #: 104917		0712697628-00002 Mukw Dam	100-5254-522200	23.16	
		Vnd: 0034 Invoice: 5384441096	100-0000-211000		23.16
		Expected Check Run: 03/04/2025		<u>23.16</u>	<u>23.16</u>
03/21/2025	AP	WE ENERGIES	Invoice: 5384441096 Ref#: 69404(0712697628-00003 PD Tower meter #05662)		
AP Trx #: 104918		0712697628-00003 PD Tower meter #05662	100-5211-522200	21.09	
		Vnd: 0034 Invoice: 5384441096	100-0000-211000		21.09
		Expected Check Run: 03/04/2025		<u>21.09</u>	<u>21.09</u>
03/21/2025	AP	WE ENERGIES	Invoice: 5384441096 Ref#: 69405(0712697628-00004 1224 Riverton)		
AP Trx #: 104919		0712697628-00004 1224 Riverton	620-8020-821000	171.19	
		Vnd: 0034 Invoice: 5384441096	620-0000-211000		171.19
		Expected Check Run: 03/04/2025		<u>171.19</u>	<u>171.19</u>
03/21/2025	AP	WE ENERGIES	Invoice: 5384441096 Ref#: 69406(0712697628-00006 Well #7)		
AP Trx #: 104920		0712697628-00006 Well #7	610-6200-662200	773.33	
		Vnd: 0034 Invoice: 5384441096	610-0000-211000		773.33
		Expected Check Run: 03/04/2025		<u>773.33</u>	<u>773.33</u>
03/21/2025	AP	WE ENERGIES	Invoice: 5384441096 Ref#: 69407(0712697628-00007 School Crossing Lights)		
AP Trx #: 104921		0712697628-00007 School Crossing Lights	100-5342-522200	14.73	
		Vnd: 0034 Invoice: 5384441096	100-0000-211000		14.73
		Expected Check Run: 03/04/2025		<u>14.73</u>	<u>14.73</u>
03/21/2025	AP	WE ENERGIES	Invoice: 5384441096 Ref#: 69408(0712697628-00008 Field Park Signage)		
AP Trx #: 104922		0712697628-00008 Field Park Signage	100-5521-522200	40.38	
		Vnd: 0034 Invoice: 5384441096	100-0000-211000		40.38
		Expected Check Run: 03/04/2025		<u>40.38</u>	<u>40.38</u>

User: BKEIZER

BANK CODE: GEN PAY BY: PAPER CHECK CHECK RUN DATES 03/04/2025 - 03/04/2025

DB: Mukwonago

Post Date	Journal	Description	GL Number	DR Amount	CR Amount
03/21/2025	AP	WE ENERGIES	Invoice: 5384441096 Ref#: 69409(0700126680-00015 STREET LIGHTS)		
AP Trx #: 104923		0700126680-00015 STREET LIGHTS	100-5342-522200	10,798.65	
		Vnd: 0034 Invoice: 5384441096	100-0000-211000		10,798.65
		Expected Check Run: 03/04/2025			
				<u>10,798.65</u>	<u>10,798.65</u>
				<u>55,769.19</u>	<u>55,769.19</u>
Cash/Payable Account Totals:					
		VOUCHERS PAYABLE	100-0000-211000		21,918.78
		VOUCHERS PAYABLE	150-0000-211000		2,922.92
		VOUCHERS PAYABLE	440-0000-211000		5,971.14
		VOUCHERS PAYABLE	610-0000-211000		12,153.63
		VOUCHERS PAYABLE	620-0000-211000		12,802.72
			TOTAL INCREASE IN PAYABI		55,769.19

Post Date	Journal	Description	GL Number	DR Amount	CR Amount
03/06/2025	AP	TREASURER STATE OF WI			
AP Trx #: 105044					
		FEB 2025 COURT FINES & FEES	100-0000-242400	6,626.15	
		Vnd: 0222 Invoice: FEB 2025	100-0000-211000		6,626.15
		Expected Check Run: 03/06/2025			
				6,626.15	6,626.15
03/06/2025	AP	TREASURER WAUKESHA COUNTY			
AP Trx #: 105045					
		FEB 2025 COURT FINES & FEES	100-0000-243240	1,747.36	
		Vnd: 0223 Invoice: FEB 2025	100-0000-211000		1,747.36
		Expected Check Run: 03/06/2025			
				1,747.36	1,747.36
				8,373.51	8,373.51
Cash/Payable Account Totals:					
		VOUCHERS PAYABLE	100-0000-211000		8,373.51
			TOTAL INCREASE IN PAYABI		8,373.51

Post Date	Journal	Description	GL Number	DR Amount	CR Amount
03/20/2025	AP	CHARTER COMMUNICATIONS	Invoice: 152486401022125 Ref#: 69436 (MARCH 2025 MONTHLY BILL)		
AP Trx #:	105053				
		COURT	100-5120-522500	19.47	
		ADMIN	100-5141-522500	8.24	
		CLERK	100-5142-522500	67.95	
		VH ALARM SYSTEM	100-5160-522500	26.95	
		POLICE	100-5211-522500	290.49	
		BLDG INSP	100-5241-522500	19.45	
		DPW	100-5323-522500	38.20	
		MUSEUM	100-5512-522500	139.99	
		FIRE	150-5221-522500	190.25	
		RECYCLING	410-5363-522500	2.16	
		LIBRARY	440-5511-522500	152.05	
		STORM WATER	500-5344-522500	1.08	
		WATER	610-6920-692100	18.34	
		SEWER	620-8400-851000	18.34	
		FINANCE	100-5145-522900	32.96	
		Vnd: 3200 Invoice: 152486401022125	100-0000-211000		643.70
		Vnd: 3200 Invoice: 152486401022125	150-0000-211000		190.25
		Vnd: 3200 Invoice: 152486401022125	410-0000-211000		2.16
		Vnd: 3200 Invoice: 152486401022125	440-0000-211000		152.05
		Vnd: 3200 Invoice: 152486401022125	500-0000-211000		1.08
		Vnd: 3200 Invoice: 152486401022125	610-0000-211000		18.34
		Vnd: 3200 Invoice: 152486401022125	620-0000-211000		18.34
		Expected Check Run: 03/20/2025			
				1,025.92	1,025.92
				<u>1,025.92</u>	<u>1,025.92</u>
Cash/Payable Account Totals:					
		VOUCHERS PAYABLE	100-0000-211000		643.70
		VOUCHERS PAYABLE	150-0000-211000		190.25
		VOUCHERS PAYABLE	410-0000-211000		2.16
		VOUCHERS PAYABLE	440-0000-211000		152.05
		VOUCHERS PAYABLE	500-0000-211000		1.08
		VOUCHERS PAYABLE	610-0000-211000		18.34
		VOUCHERS PAYABLE	620-0000-211000		18.34
		GRAND TOTAL:			<u>1,025.92</u>

User: BKEIZER

BANK CODE: GEN PAY BY: PAPER CHECK CHECK RUN DATES 03/12/2025 - 03/12/2025

DB: Mukwonago

Post Date	Journal	Description	GL Number	DR Amount	CR Amount
03/12/2025	AP	SECURIAN FINANCIAL GROUP INC	Invoice: 76038-MAR2025 Ref#: 69528 (MAR 2025 ACCIDENT INSURANCE)		
AP Trx #: 105048		ACCIDENT - SUPPLEMENTAL INSURANCE	100-0000-215305	81.80	
		ACCIDENT - SUPPLEMENTAL INSURANCE	150-0000-215305	10.88	
		ACCIDENT - SUPPLEMENTAL INSURANCE	440-0000-215305	3.96	
		Vnd: 3136 Invoice: 76038-MAR2025	100-0000-211000		81.80
		Vnd: 3136 Invoice: 76038-MAR2025	150-0000-211000		10.88
		Vnd: 3136 Invoice: 76038-MAR2025	440-0000-211000		3.96
		Expected Check Run: 03/12/2025		96.64	96.64
03/12/2025	AP	SECURIAN FINANCIAL GROUP INC	Invoice: 002832L-MAR25 Ref#: 69529 (LIFE INSURANCE APRIL 2025 PREM)		
AP Trx #: 105049		LIFE INSURANCE PAYABLE	100-0000-215301	1,354.71	
		LIFE INSURANCE PAYABLE	150-0000-215301	238.97	
		LIFE INSURANCE PAYABLE	440-0000-215301	104.31	
		LIFE INSURANCE PAYABLE	610-0000-215301	40.32	
		LIFE INSURANCE PAYABLE	620-0000-215301	188.33	
		Vnd: 3136 Invoice: 002832L-MAR25	100-0000-211000		1,354.71
		Vnd: 3136 Invoice: 002832L-MAR25	150-0000-211000		238.97
		Vnd: 3136 Invoice: 002832L-MAR25	440-0000-211000		104.31
		Vnd: 3136 Invoice: 002832L-MAR25	610-0000-211000		40.32
		Vnd: 3136 Invoice: 002832L-MAR25	620-0000-211000		188.33
		Expected Check Run: 03/12/2025		1,926.64	1,926.64
Cash/Payable Account Totals:				2,023.28	2,023.28
		VOUCHERS PAYABLE	100-0000-211000		1,436.51
		VOUCHERS PAYABLE	150-0000-211000		249.85
		VOUCHERS PAYABLE	440-0000-211000		108.27
		VOUCHERS PAYABLE	610-0000-211000		40.32
		VOUCHERS PAYABLE	620-0000-211000		188.33
		TOTAL INCREASE IN PAYABI			2,023.28

Post Date	Journal	Description	GL Number	DR Amount	CR Amount
03/12/2025	AP	GREAT WEST RETIREMENT SERVICES	Invoice: PR 031425 Ref#: 69530 (RETIREMENT SAVINGS 03-14-25 PR)		
AP Trx #: 105051					
		DEFERRED COMPENSATION	100-0000-215250	794.42	
		DEFERRED COMPENSATION	150-0000-215250	2,771.40	
		Vnd: 0005 Invoice: PR 031425	100-0000-211000		794.42
		Vnd: 0005 Invoice: PR 031425	150-0000-211000		2,771.40
		Expected Check Run: 03/12/2025			
				3,565.82	3,565.82
03/12/2025	AP	MISSION SQUARE	Invoice: PR031425 Ref#: 69531 (RETIREMENT SAVINGS 03-14-25 PR)		
AP Trx #: 105052					
		DEFERRED COMPENSATION	100-0000-215250	4,101.05	
		DEFERRED COMPENSATION	150-0000-215250	50.00	
		DEFERRED COMPENSATION	440-0000-215250	1,004.37	
		DEFERRED COMPENSATION	610-0000-215250	186.40	
		DEFERRED COMPENSATION	620-0000-215250	272.75	
		Vnd: 0010 Invoice: PR031425	100-0000-211000		4,101.05
		Vnd: 0010 Invoice: PR031425	150-0000-211000		50.00
		Vnd: 0010 Invoice: PR031425	440-0000-211000		1,004.37
		Vnd: 0010 Invoice: PR031425	610-0000-211000		186.40
		Vnd: 0010 Invoice: PR031425	620-0000-211000		272.75
		Expected Check Run: 03/12/2025			
				5,614.57	5,614.57
				9,180.39	9,180.39
Cash/Payable Account Totals:					
		VOUCHERS PAYABLE	100-0000-211000		4,895.47
		VOUCHERS PAYABLE	150-0000-211000		2,821.40
		VOUCHERS PAYABLE	440-0000-211000		1,004.37
		VOUCHERS PAYABLE	610-0000-211000		186.40
		VOUCHERS PAYABLE	620-0000-211000		272.75
			TOTAL INCREASE IN PAYABI		9,180.39

Post Date	Journal	Description	GL Number	DR Amount	CR Amount
03/14/2025	AP	ALSCO			
AP Trx #: 105057		Invoice: IMIL2095630 Ref#: 69299 (MATS & DUSTERS)			
		OUTSIDE SERVICES	440-5511-531000	95.56	
		Vnd: 2950 Invoice: IMIL2095630	440-0000-211000		95.56
		Expected Check Run: 03/14/2025		<u>95.56</u>	<u>95.56</u>
03/14/2025	AP	AMAZON CAPITOL SERVICES			
AP Trx #: 105058		Invoice: 1DNY-WL6K-31DQ Ref#: 69419 (OFFICE SUPPLIES)			
		OPERATIONAL SUPPLIES	440-5511-531100	76.54	
		Vnd: 3189 Invoice: 1DNY-WL6K-31DQ	440-0000-211000		76.54
		Expected Check Run: 03/14/2025		<u>76.54</u>	<u>76.54</u>
03/14/2025	AP	AMAZON CAPITOL SERVICES			
AP Trx #: 105059		Invoice: 17QR-3YHT-4QLY Ref#: 69420 (PROGRAM SUPPLIES)			
		METASPACE MAINTENANCE	440-5511-531700	336.69	
		Vnd: 3189 Invoice: 17QR-3YHT-4QLY	440-0000-211000		336.69
		Expected Check Run: 03/14/2025		<u>336.69</u>	<u>336.69</u>
03/14/2025	AP	AMAZON CAPITOL SERVICES			
AP Trx #: 105060		Invoice: 1GRC-N3LW-34QW Ref#: 69421 (THINGERY SUPPLIES)			
		THINGERY MAINTENANCE	440-5511-531800	55.57	
		Vnd: 3189 Invoice: 1GRC-N3LW-34QW	440-0000-211000		55.57
		Expected Check Run: 03/14/2025		<u>55.57</u>	<u>55.57</u>
03/14/2025	AP	AMAZON CAPITOL SERVICES			
AP Trx #: 105061		Invoice: 1KRN-R3YQ-674K Ref#: 69422 (BOOKS)			
		BOOKS	440-5700-532800	141.81	
		Vnd: 3189 Invoice: 1KRN-R3YQ-674K	440-0000-211000		141.81
		Expected Check Run: 03/14/2025		<u>141.81</u>	<u>141.81</u>
03/14/2025	AP	AMAZON CAPITOL SERVICES			
AP Trx #: 105062		Invoice: 1HCV-RR7P-1LM9 Ref#: 69423 (BOOKS)			
		BOOKS	440-5700-532800	60.59	
		Vnd: 3189 Invoice: 1HCV-RR7P-1LM9	440-0000-211000		60.59
		Expected Check Run: 03/14/2025		<u>60.59</u>	<u>60.59</u>

Post Date	Journal	Description	GL Number	DR Amount	CR Amount
03/14/2025	AP	AMAZON CAPITOL SERVICES			
AP Trx #: 105063					
		AV MATERIAL	440-5700-532900	310.47	
		Vnd: 3189 Invoice: 1WML-WJDF-4W9R	440-0000-211000		310.47
		Expected Check Run: 03/14/2025			
				<u>310.47</u>	<u>310.47</u>
03/14/2025	AP	AMAZON CAPITOL SERVICES			
AP Trx #: 105064					
		AV MATERIAL	440-5700-532900	49.56	
		Vnd: 3189 Invoice: 1LJR-N4TG-YFVH	440-0000-211000		49.56
		Expected Check Run: 03/14/2025			
				<u>49.56</u>	<u>49.56</u>
03/14/2025	AP	AMAZON CAPITOL SERVICES			
AP Trx #: 105065					
		PROGRAMMING	440-5511-533100	107.38	
		Vnd: 3189 Invoice: 17QR-3YHT-46Q9	440-0000-211000		107.38
		Expected Check Run: 03/14/2025			
				<u>107.38</u>	<u>107.38</u>
03/14/2025	AP	AMAZON CAPITOL SERVICES			
AP Trx #: 105066					
		PROGRAMMING	440-5511-533100	117.08	
		Vnd: 3189 Invoice: 11DX-YVLL-4CXR	440-0000-211000		117.08
		Expected Check Run: 03/14/2025			
				<u>117.08</u>	<u>117.08</u>
03/14/2025	AP	AMAZON CAPITOL SERVICES			
AP Trx #: 105067					
		PROGRAMMING	440-5511-533100		56.99
		Vnd: 3189 Invoice: 1XLY-61Y4-4RW1	440-0000-211000	56.99	
		Expected Check Run: 03/14/2025			
				<u>56.99</u>	<u>56.99</u>
03/14/2025	AP	AMAZON CAPITOL SERVICES			
AP Trx #: 105068					
		DONATED FUND EXPENDITURES	440-5890-580600	245.00	
		Vnd: 3189 Invoice: 1LKX-JHTG-6HHP	440-0000-211000		245.00
		Expected Check Run: 03/14/2025			
				<u>245.00</u>	<u>245.00</u>

Post Date	Journal	Description	GL Number	DR Amount	CR Amount
03/14/2025	AP	AMERICA AQUARIA			
AP Trx #: 105069					
		OUTSIDE SERVICES	440-5511-531000	85.00	
		Vnd: 1792 Invoice: 56666	440-0000-211000		85.00
		Expected Check Run: 03/14/2025			
				<u>85.00</u>	<u>85.00</u>
03/14/2025	AP	BAKER & TAYLOR INC.			
AP Trx #: 105070					
		BOOKS	440-5700-532800	31.01	
		Vnd: 0044 Invoice: 2038871233	440-0000-211000		31.01
		Expected Check Run: 03/14/2025			
				<u>31.01</u>	<u>31.01</u>
03/14/2025	AP	BAKER & TAYLOR INC.			
AP Trx #: 105071					
		BOOKS	440-5700-532800	178.53	
		Vnd: 0044 Invoice: 2038871234	440-0000-211000		178.53
		Expected Check Run: 03/14/2025			
				<u>178.53</u>	<u>178.53</u>
03/14/2025	AP	BAKER & TAYLOR INC.			
AP Trx #: 105072					
		BOOKS	440-5700-532800	25.64	
		Vnd: 0044 Invoice: 2038871235	440-0000-211000		25.64
		Expected Check Run: 03/14/2025			
				<u>25.64</u>	<u>25.64</u>
03/14/2025	AP	BAKER & TAYLOR INC.			
AP Trx #: 105073					
		BOOKS	440-5700-532800	334.58	
		Vnd: 0044 Invoice: 2038871236	440-0000-211000		334.58
		Expected Check Run: 03/14/2025			
				<u>334.58</u>	<u>334.58</u>
03/14/2025	AP	BAKER & TAYLOR INC.			
AP Trx #: 105074					
		BOOKS	440-5700-532800	3.85	
		Vnd: 0044 Invoice: 2038876916	440-0000-211000		3.85
		Expected Check Run: 03/14/2025			
				<u>3.85</u>	<u>3.85</u>

Post Date	Journal	Description	GL Number	DR Amount	CR Amount
03/14/2025	AP	BAKER & TAYLOR INC.			
AP Trx #: 105075					
		BOOKS	440-5700-532800	162.82	
		Vnd: 0044 Invoice: 2038876917	440-0000-211000		162.82
		Expected Check Run: 03/14/2025			
				<u>162.82</u>	<u>162.82</u>
03/14/2025	AP	BAKER & TAYLOR INC.			
AP Trx #: 105076					
		BOOKS	440-5700-532800	44.02	
		Vnd: 0044 Invoice: 2038876918	440-0000-211000		44.02
		Expected Check Run: 03/14/2025			
				<u>44.02</u>	<u>44.02</u>
03/14/2025	AP	BAKER & TAYLOR INC.			
AP Trx #: 105077					
		BOOKS	440-5700-532800	322.65	
		Vnd: 0044 Invoice: 2038876919	440-0000-211000		322.65
		Expected Check Run: 03/14/2025			
				<u>322.65</u>	<u>322.65</u>
03/14/2025	AP	BAKER & TAYLOR INC.			
AP Trx #: 105078					
		BOOKS	440-5700-532800	362.88	
		Vnd: 0044 Invoice: 2038883966	440-0000-211000		362.88
		Expected Check Run: 03/14/2025			
				<u>362.88</u>	<u>362.88</u>
03/14/2025	AP	BAKER & TAYLOR INC.			
AP Trx #: 105079					
		BOOKS	440-5700-532800	250.42	
		Vnd: 0044 Invoice: 2038883967	440-0000-211000		250.42
		Expected Check Run: 03/14/2025			
				<u>250.42</u>	<u>250.42</u>
03/14/2025	AP	BAKER & TAYLOR INC.			
AP Trx #: 105080					
		BOOKS	440-5700-532800	77.15	
		Vnd: 0044 Invoice: 2038883968	440-0000-211000		77.15
		Expected Check Run: 03/14/2025			
				<u>77.15</u>	<u>77.15</u>

Post Date	Journal	Description	GL Number	DR Amount	CR Amount
03/14/2025	AP	BAKER & TAYLOR INC.			
AP Trx #: 105081					
		BOOKS	440-5700-532800	33.44	
		Vnd: 0044 Invoice: 2038900797	440-0000-211000		33.44
		Expected Check Run: 03/14/2025			
				<u>33.44</u>	<u>33.44</u>
03/14/2025	AP	BAKER & TAYLOR INC.			
AP Trx #: 105082					
		BOOKS	440-5700-532800	47.97	
		Vnd: 0044 Invoice: 2038900798	440-0000-211000		47.97
		Expected Check Run: 03/14/2025			
				<u>47.97</u>	<u>47.97</u>
03/14/2025	AP	BAKER & TAYLOR INC.			
AP Trx #: 105083					
		BOOKS	440-5700-532800	24.48	
		Vnd: 0044 Invoice: 2038900799	440-0000-211000		24.48
		Expected Check Run: 03/14/2025			
				<u>24.48</u>	<u>24.48</u>
03/14/2025	AP	BAKER & TAYLOR INC.			
AP Trx #: 105084					
		BOOKS	440-5700-532800	189.23	
		Vnd: 0044 Invoice: 2038900800	440-0000-211000		189.23
		Expected Check Run: 03/14/2025			
				<u>189.23</u>	<u>189.23</u>
03/14/2025	AP	BAKER & TAYLOR INC.			
AP Trx #: 105085					
		BOOKS	440-5700-532800	16.46	
		Vnd: 0044 Invoice: 2038901318	440-0000-211000		16.46
		Expected Check Run: 03/14/2025			
				<u>16.46</u>	<u>16.46</u>
03/14/2025	AP	BAKER & TAYLOR INC.			
AP Trx #: 105086					
		BOOKS	440-5700-532800	365.24	
		Vnd: 0044 Invoice: 2038901319	440-0000-211000		365.24
		Expected Check Run: 03/14/2025			
				<u>365.24</u>	<u>365.24</u>

Post Date	Journal	Description	GL Number	DR Amount	CR Amount
03/14/2025	AP	BERNSTEIN & ASSOCIATES, LLC			
AP Trx #: 105087					
		DONATED FUND EXPENDITURES	440-5890-580600	440.00	
		Vnd: 3268 Invoice: 3045	440-0000-211000		440.00
		Expected Check Run: 03/14/2025			
				<u>440.00</u>	<u>440.00</u>
03/14/2025	AP	BLACKSTONE PUBLISHING			
AP Trx #: 105088					
		AV MATERIAL	440-5700-532900	42.91	
		Vnd: 1107 Invoice: 2188958	440-0000-211000		42.91
		Expected Check Run: 03/14/2025			
				<u>42.91</u>	<u>42.91</u>
03/14/2025	AP	BRODART			
AP Trx #: 105089					
		BOOKS	440-5700-532800	155.02	
		Vnd: 0987 Invoice: B6931286	440-0000-211000		155.02
		Expected Check Run: 03/14/2025			
				<u>155.02</u>	<u>155.02</u>
03/14/2025	AP	BRODART			
AP Trx #: 105090					
		BOOKS	440-5700-532800	397.50	
		Vnd: 0987 Invoice: B6932396	440-0000-211000		397.50
		Expected Check Run: 03/14/2025			
				<u>397.50</u>	<u>397.50</u>
03/14/2025	AP	BRODART			
AP Trx #: 105091					
		BOOKS	440-5700-532800	84.55	
		Vnd: 0987 Invoice: B6934275	440-0000-211000		84.55
		Expected Check Run: 03/14/2025			
				<u>84.55</u>	<u>84.55</u>
03/14/2025	AP	BRODART			
AP Trx #: 105092					
		BOOKS	440-5700-532800	105.78	
		Vnd: 0987 Invoice: B6940041	440-0000-211000		105.78
		Expected Check Run: 03/14/2025			
				<u>105.78</u>	<u>105.78</u>

Post Date	Journal	Description	GL Number	DR Amount	CR Amount
03/14/2025	AP	BRODART			
AP Trx #: 105093					
		BOOKS	440-5700-532800	131.28	
		Vnd: 0987 Invoice: B6944503	440-0000-211000		131.28
		Expected Check Run: 03/14/2025		<u>131.28</u>	<u>131.28</u>
03/14/2025	AP	COMPLETE OFFICE OF WISCONSIN			
AP Trx #: 105094					
		OPERATIONAL SUPPLIES	440-5511-531100	73.08	
		Vnd: 3340 Invoice: 874074	440-0000-211000		73.08
		Expected Check Run: 03/14/2025		<u>73.08</u>	<u>73.08</u>
03/14/2025	AP	COVER ONE			
AP Trx #: 105095					
		EQUIPMENT LESS THAN \$5000	440-5511-581100	1,339.00	
		Vnd: 3394 Invoice: 26346	440-0000-211000		1,339.00
		Expected Check Run: 03/14/2025		<u>1,339.00</u>	<u>1,339.00</u>
03/14/2025	AP	EMILY CEITHAMER			
AP Trx #: 105096					
		MILEAGE	440-5511-533200	49.00	
		Vnd: 3275 Invoice: FEBRUARY	440-0000-211000		49.00
		Expected Check Run: 03/14/2025		<u>49.00</u>	<u>49.00</u>
03/14/2025	AP	EMMA PLITZNER			
AP Trx #: 105097					
		MILEAGE	440-5511-533200	9.10	
		Vnd: MISC Invoice: FEBRUARY	440-0000-211000		9.10
		Expected Check Run: 03/14/2025		<u>9.10</u>	<u>9.10</u>
03/14/2025	AP	GREAT AMERICAN FINANCIAL SVCS.			
AP Trx #: 105098					
		CONTRACTUAL SERVICES	440-5511-522000	403.19	
		Vnd: 1290 Invoice: 38630891	440-0000-211000		403.19
		Expected Check Run: 03/14/2025		<u>403.19</u>	<u>403.19</u>

Post Date	Journal	Description	GL Number	DR Amount	CR Amount
03/14/2025	AP	KLASSY KLEANERS	Invoice: 1061 Ref#: 69418 (WEEKEND CLEANING)		
AP Trx #: 105099		OUTSIDE SERVICES	440-5511-531000	960.00	
		Vnd: 3114 Invoice: 1061	440-0000-211000		960.00
		Expected Check Run: 03/14/2025		<u>960.00</u>	<u>960.00</u>
03/14/2025	AP	MAXIMUM MACHINE SERVICES	Invoice: 000025 Ref#: 69444 (EPILOG LASER SERVICE)		
AP Trx #: 105100		METASPACE MAINTENANCE	440-5511-531700	350.00	
		Vnd: 3395 Invoice: 000025	440-0000-211000		350.00
		Expected Check Run: 03/14/2025		<u>350.00</u>	<u>350.00</u>
03/14/2025	AP	MIDWEST TAPE	Invoice: 506824213 Ref#: 69417 (HOOPLA)		
AP Trx #: 105101		DIGITAL COLLECTIONS	440-5511-534900	875.48	
		Vnd: 0074 Invoice: 506824213	440-0000-211000		875.48
		Expected Check Run: 03/14/2025		<u>875.48</u>	<u>875.48</u>
03/14/2025	AP	PLAYAWAY PRODUCTS LLC	Invoice: 491038 Ref#: 69440 (LAUNCHPADS)		
AP Trx #: 105102		THINGERY COLLECTION	440-5511-533000	1,969.88	
		Vnd: 3341 Invoice: 491038	440-0000-211000		1,969.88
		Expected Check Run: 03/14/2025		<u>1,969.88</u>	<u>1,969.88</u>
03/14/2025	AP	QUILL LLC	Invoice: 42935740 Ref#: 69303 (CLEANING SUPPLIES)		
AP Trx #: 105103		OPERATIONAL SUPPLIES	440-5511-531100	33.58	
		Vnd: 0084 Invoice: 42935740	440-0000-211000		33.58
		Expected Check Run: 03/14/2025		<u>33.58</u>	<u>33.58</u>
03/14/2025	AP	SCOTT OBERMANN	Invoice: 031825ML Ref#: 69441 (MAGIC OF DREAMING BIG SHOW)		
AP Trx #: 105104		PROGRAMMING	440-5511-533100	400.00	
		Vnd: 3396 Invoice: 031825ML	440-0000-211000		400.00
		Expected Check Run: 03/14/2025		<u>400.00</u>	<u>400.00</u>

Post Date	Journal	Description	GL Number	DR Amount	CR Amount
03/14/2025	AP	TAYLOR COMPUTER SERVICES, INC			
AP Trx #: 105105					
		CONTRACTUAL SERVICES	440-5511-522000	612.00	
		Vnd: 1295 Invoice: 27445	440-0000-211000		612.00
		Expected Check Run: 03/14/2025			
				<u>612.00</u>	<u>612.00</u>
03/14/2025	AP	THE PENWORTHY COMPANY LLC			
AP Trx #: 105106					
		BOOKS	440-5700-532800	662.49	
		Vnd: 3367 Invoice: 0606250-IN	440-0000-211000		662.49
		Expected Check Run: 03/14/2025			
				<u>662.49</u>	<u>662.49</u>
03/14/2025	AP	THOMAS PRESS, INC.			
AP Trx #: 105107					
		OUTREACH	440-5511-533300	86.00	
		Vnd: 3247 Invoice: 10870-25	440-0000-211000		86.00
		Expected Check Run: 03/14/2025			
				<u>86.00</u>	<u>86.00</u>
03/14/2025	AP	THOMAS PRESS, INC.			
AP Trx #: 105108					
		OUTREACH	440-5511-533300	95.30	
		Vnd: 3247 Invoice: 10866-25	440-0000-211000		95.30
		Expected Check Run: 03/14/2025			
				<u>95.30</u>	<u>95.30</u>
03/14/2025	AP	UNITED STATES ALLIANCE FIRE PROTECT			
AP Trx #: 105109					
		REPAIRS & MAINTENANCE	440-5511-539500	1,865.00	
		Vnd: 0588 Invoice: 1046-F147877	440-0000-211000		1,865.00
		Expected Check Run: 03/14/2025			
				<u>1,865.00</u>	<u>1,865.00</u>
Cash/Payable Account Totals:					
		VOUCHERS PAYABLE	440-0000-211000		15,234.77
			TOTAL INCREASE IN PAYABI		15,234.77
				<u>15,348.75</u>	<u>15,348.75</u>

Post Date	Journal	Description	GL Number	DR Amount	CR Amount
03/21/2025	AP	TOWN OF MUKWONAGO	Invoice: 2024 SETTLEMENT Ref#: 69677(2024 FIRE DEPT SETTLEMENT)		
AP Trx #: 105331		DUE TO TOWN OF MUKWONAGO	150-0000-244100	309,974.29	
		Vnd: 0361 Invoice: 2024 SETTLEMENT	150-0000-211000		309,974.29
		Expected Check Run: 03/21/2025			
				<u>309,974.29</u>	<u>309,974.29</u>
				<u>309,974.29</u>	<u>309,974.29</u>
Cash/Payable Account Totals:		VOUCHERS PAYABLE	150-0000-211000		309,974.29
			GRAND TOTAL:		<u>309,974.29</u>

Post Date	Journal	Description	GL Number	DR Amount	CR Amount
03/21/2025	AP	ENVIROTECH EQUIPMENT	Invoice: 25-0024896 Ref#: 69676 (VACCON TRUCK)		
AP Trx #: 105333		OTHER COLLECTION SYSTEM EQUIP	620-0000-135350	622,173.00	
		Vnd: 1890 Invoice: 25-0024896	620-0000-211000		622,173.00
		Expected Check Run: 03/21/2025			
				<u>622,173.00</u>	<u>622,173.00</u>
				<u>622,173.00</u>	<u>622,173.00</u>
Cash/Payable Account Totals:		VOUCHERS PAYABLE	620-0000-211000		622,173.00
			GRAND TOTAL:		<u>622,173.00</u>

Post Date	Journal	Description	GL Number	DR Amount	CR Amount
03/25/2025	AP	AFLAC	Invoice: 393032 Ref#: 69742 (ACCOUNT# V1553 MARCH 2025 SUPPLEMENTAL I)		
AP Trx #: 105335		MARCH 2025 SUPPLEMENTAL INSURANCE	100-0000-215302	501.24	
		MARCH 2025 SUPPLEMENTAL INSURANCE	150-0000-215302	307.72	
		MARCH 2025 SUPPLEMENTAL INSURANCE	610-0000-215302	126.00	
		MARCH 2025 SUPPLEMENTAL INSURANCE	620-0000-215302	107.38	
		ADJ MARCH 2025	100-0000-215302		0.02
		Vnd: 0004 Invoice: 393032	100-0000-211000		501.22
		Vnd: 0004 Invoice: 393032	150-0000-211000		307.72
		Vnd: 0004 Invoice: 393032	610-0000-211000		126.00
		Vnd: 0004 Invoice: 393032	620-0000-211000		107.38
		Expected Check Run: 03/25/2025		<u>1,042.34</u>	<u>1,042.34</u>
03/25/2025	AP	MUKWONAGO PROFESSIONAL	Invoice: MARCH 2025 Ref#: 69740 (MARCH 2025 FIRE UNION DUES)		
AP Trx #: 105336		UNION DUES PAYABLE	150-0000-215500	900.00	
		Vnd: 0017 Invoice: MARCH 2025	150-0000-211000		900.00
		Expected Check Run: 03/25/2025		<u>900.00</u>	<u>900.00</u>
03/25/2025	AP	MUKWONAGO PROFESSIONAL POLICE	Invoice: MARCH 2025 Ref#: 69743 (MARCH 2025 POLICE UNION DUES)		
AP Trx #: 105337		UNION DUES PAYABLE	100-0000-215500	550.00	
		Vnd: 0016 Invoice: MARCH 2025	100-0000-211000		550.00
		Expected Check Run: 03/25/2025		<u>550.00</u>	<u>550.00</u>
03/25/2025	AP	VILLAGE OF MUKWONAGO MRA	Invoice: MARCH 2025 Ref#: 69744 (MARCH 2025 FSA)		
AP Trx #: 105338		MARCH 2025 FSA	100-0000-215350	2,025.57	
		MARCH 2025 FSA	150-0000-215350	970.55	
		MARCH 2025 FSA	440-0000-215350	40.00	
		MARCH 2025 FSA	620-0000-215350	228.56	
		FLEXIBLE SPENDING CONTRIBUTION	610-0000-215350	6.06	
		Vnd: 0018 Invoice: MARCH 2025	100-0000-211000		2,025.57
		Vnd: 0018 Invoice: MARCH 2025	150-0000-211000		970.55
		Vnd: 0018 Invoice: MARCH 2025	440-0000-211000		40.00
		Vnd: 0018 Invoice: MARCH 2025	620-0000-211000		228.56
		Vnd: 0018 Invoice: MARCH 2025	610-0000-211000		6.06
		Expected Check Run: 03/25/2025		<u>3,270.74</u>	<u>3,270.74</u>
				<u>5,763.08</u>	<u>5,763.08</u>

Cash/Payable Account Totals:

VOUCHERS PAYABLE	100-0000-211000	3,076.79
VOUCHERS PAYABLE	150-0000-211000	2,178.27
VOUCHERS PAYABLE	440-0000-211000	40.00
VOUCHERS PAYABLE	610-0000-211000	132.00

Post Date	Journal	Description	GL Number	DR Amount	CR Amount
		VOUCHERS PAYABLE	620-0000-211000		335.94
			TOTAL INCREASE IN PAYABI		5,763.06

Post Date	Journal	Description	GL Number	DR Amount	CR Amount
03/18/2025	AP	ADAGIO TEAS	Invoice: ARMOUR ABBY Ref#: 69571 (TEA GIVEAWAY)		
AP Trx #: 105359		PROGRAMMING	440-5511-533100	41.75	
		Vnd: MISCCC Invoice: ARMOUR ABBY	440-0000-211000		41.75
		Expected Check Run: 03/26/2025		<u>41.75</u>	<u>41.75</u>
03/18/2025	AP	ADOBE *ADOBE	Invoice: ARMOUR ABBY Ref#: 69572 (CREATIVE CLOUD)		
AP Trx #: 105360		OUTREACH	440-5511-533300	34.99	
		Vnd: MISCCC Invoice: ARMOUR ABBY	440-0000-211000		34.99
		Expected Check Run: 03/26/2025		<u>34.99</u>	<u>34.99</u>
03/18/2025	AP	AGRECOL LLC	Invoice: PRIDE JAMES Ref#: 69619 (SEEDS FOR SEED LIBRARY)		
AP Trx #: 105361		PROGRAMMING	440-5511-533100	227.01	
		Vnd: MISCCC Invoice: PRIDE JAMES	440-0000-211000		227.01
		Expected Check Run: 03/26/2025		<u>227.01</u>	<u>227.01</u>
03/18/2025	AP	AMAZON MKTPL*3933E1P93	Invoice: CASTLE WAYNE A Ref#: 69578 (OFFICE SUPPLIES)		
AP Trx #: 105362		OFFICE SUPPLIES & EXPENSES	610-6920-692100	157.01	
		OFFICE SUPPLIES & EXPENSES	620-8400-851000	157.02	
		Vnd: MISCCC Invoice: CASTLE WAYNE A	610-0000-211000		157.01
		Vnd: MISCCC Invoice: CASTLE WAYNE A	620-0000-211000		157.02
		Expected Check Run: 03/26/2025		<u>314.03</u>	<u>314.03</u>
03/18/2025	AP	AMAZON MKTPL*9F31K4413	Invoice: DEMOTTO CHRIS Ref#: 69595 (RESERVE OFFICER NAME TAPES)		
AP Trx #: 105363		NEW UNIFORM ISSUE	100-5212-534700	34.95	
		Vnd: MISCCC Invoice: DEMOTTO CHRIS	100-0000-211000		34.95
		Expected Check Run: 03/26/2025		<u>34.95</u>	<u>34.95</u>
03/18/2025	AP	AMAZON MKTPL*J71IY0JM3	Invoice: CASTLE WAYNE A Ref#: 69581 (OFFICE SUPPLIES)		
AP Trx #: 105364		OFFICE SUPPLIES & EXPENSES	610-6920-692100	20.49	
		OFFICE SUPPLIES & EXPENSES	620-8400-851000	20.48	
		Vnd: MISCCC Invoice: CASTLE WAYNE A	610-0000-211000		20.49
		Vnd: MISCCC Invoice: CASTLE WAYNE A	620-0000-211000		20.48
		Expected Check Run: 03/26/2025		<u>40.97</u>	<u>40.97</u>

Post Date	Journal	Description	GL Number	DR Amount	CR Amount
03/18/2025	AP	AMERICAN RED CROSS			
AP Trx #: 105365					
		TRAINING & TRAVEL	100-5211-533500	33.30	
		Vnd: MISCCC Invoice: ZAESKE DEBBIE	100-0000-211000		33.30
		Expected Check Run: 03/26/2025		<u>33.30</u>	<u>33.30</u>
03/18/2025	AP	AMERICAN RED CROSS			
AP Trx #: 105366					
		TRAINING & TRAVEL	100-5211-533500	185.00	
		Vnd: MISCCC Invoice: ZAESKE DEBBIE	100-0000-211000		185.00
		Expected Check Run: 03/26/2025		<u>185.00</u>	<u>185.00</u>
03/18/2025	AP	ANN*COUNTRY SAMPLER			
AP Trx #: 105367					
		PERIODICALS	440-5511-532600	24.00	
		Vnd: MISCCC Invoice: CEITHAMER EMILY	440-0000-211000		24.00
		Expected Check Run: 03/26/2025		<u>24.00</u>	<u>24.00</u>
03/18/2025	AP	APPLE.COM/BILL			
AP Trx #: 105368					
		OPERATIONAL SUPPLIES	150-5221-531100	0.99	
		Vnd: MISCCC Invoice: SURA MATTHEW J	150-0000-211000		0.99
		Expected Check Run: 03/26/2025		<u>0.99</u>	<u>0.99</u>
03/18/2025	AP	BT *FILTER PRODUCTS C			
AP Trx #: 105369					
		OPERATION SUPPLY/EXPENSE	620-8010-827000	178.58	
		Vnd: MISCCC Invoice: BROWN DAVID	620-0000-211000		178.58
		Expected Check Run: 03/26/2025		<u>178.58</u>	<u>178.58</u>
03/18/2025	AP	CANVA* I04432-69088346			
AP Trx #: 105370					
		OTHER	100-5142-539900	120.00	
		Vnd: MISCCC Invoice: KROPF LANA	100-0000-211000		120.00
		Expected Check Run: 03/26/2025		<u>120.00</u>	<u>120.00</u>

Post Date	Journal	Description	GL Number	DR Amount	CR Amount
03/18/2025	AP	CERTIF A GIFT			
AP Trx #: 105371					
		EMPLOYEE RECOGNITION	100-5141-539800	466.04	
		Vnd: MISCCC Invoice: DOHERTY DIANA	100-0000-211000		466.04
		Expected Check Run: 03/26/2025		<u>466.04</u>	<u>466.04</u>
03/18/2025	AP	CHICAGO BOOKS & JOURNALS			
AP Trx #: 105372					
		OUTREACH	440-5511-533300	22.95	
		Vnd: MISCCC Invoice: PRIDE JAMES	440-0000-211000		22.95
		Expected Check Run: 03/26/2025		<u>22.95</u>	<u>22.95</u>
03/18/2025	AP	DAVID ALAN ALAN S SMOKEHO			
AP Trx #: 105373					
		MISC GENERAL EXPENSES	610-6920-693000	350.35	
		MISC GENERAL EXPENSE	620-8400-856000	350.36	
		Vnd: MISCCC Invoice: CASTLE WAYNE A	610-0000-211000		350.35
		Vnd: MISCCC Invoice: CASTLE WAYNE A	620-0000-211000		350.36
		Expected Check Run: 03/26/2025		<u>700.71</u>	<u>700.71</u>
03/18/2025	AP	DISNEYPLUS			
AP Trx #: 105374					
		THINGERY MAINTENANCE	440-5511-531800	17.94	
		Vnd: MISCCC Invoice: CEITHAMER EMILY	440-0000-211000		17.94
		Expected Check Run: 03/26/2025		<u>17.94</u>	<u>17.94</u>
03/18/2025	AP	DNH*GODADDY#3602230996			
AP Trx #: 105375					
		SOFTWARE SUPPORT/MAINTENANCE	100-5211-522900	69.51	
		Vnd: MISCCC Invoice: KREISER ROBERT	100-0000-211000		69.51
		Expected Check Run: 03/26/2025		<u>69.51</u>	<u>69.51</u>
03/18/2025	AP	DOMINO'S 2096			
AP Trx #: 105376					
		PROGRAMMING	440-5511-533100	62.92	
		Vnd: MISCCC Invoice: CEITHAMER EMILY	440-0000-211000		62.92
		Expected Check Run: 03/26/2025		<u>62.92</u>	<u>62.92</u>

Post Date	Journal	Description	GL Number	DR Amount	CR Amount
03/18/2025	AP	DSPTS E SERVICE FEE COM			
AP Trx #: 105377					
		REPAIRS & MAINTENANCE	150-5222-539500	0.45	
		Vnd: MISCCC Invoice: KINDER MATTHEW	150-0000-211000		0.45
		Expected Check Run: 03/26/2025		<u>0.45</u>	<u>0.45</u>
03/18/2025	AP	DSPTS EPAY ISE			
AP Trx #: 105378					
		REPAIRS & MAINTENANCE	150-5222-539500	20.00	
		Vnd: MISCCC Invoice: KINDER MATTHEW	150-0000-211000		20.00
		Expected Check Run: 03/26/2025		<u>20.00</u>	<u>20.00</u>
03/18/2025	AP	EAGLE MEDIA INC.			
AP Trx #: 105379					
		CLOTHING ALLOWANCE	150-5222-534600	129.00	
		Vnd: MISCCC Invoice: STIEN JEFFREY R	150-0000-211000		129.00
		Expected Check Run: 03/26/2025		<u>129.00</u>	<u>129.00</u>
03/18/2025	AP	GRAINGER			
AP Trx #: 105380					
		OPERATION SUPPLY/EXPENSE	620-8010-827000	42.08	
		Vnd: MISCCC Invoice: BROWN DAVID	620-0000-211000		42.08
		Expected Check Run: 03/26/2025		<u>42.08</u>	<u>42.08</u>
03/18/2025	AP	GRAINGER			
AP Trx #: 105381					
		MAINT-TREATMENT/DISPOSAL PLANT	620-8010-833000	46.21	
		Vnd: MISCCC Invoice: SMITH JAMES A	620-0000-211000		46.21
		Expected Check Run: 03/26/2025		<u>46.21</u>	<u>46.21</u>
03/18/2025	AP	GRAINGER			
AP Trx #: 105382					
		MAINT-TREATMENT/DISPOSAL PLANT	620-8010-833000	46.21	
		Vnd: MISCCC Invoice: SMITH JAMES A	620-0000-211000		46.21
		Expected Check Run: 03/26/2025		<u>46.21</u>	<u>46.21</u>

Post Date	Journal	Description	GL Number	DR Amount	CR Amount
03/18/2025	AP	HELLO FLOWERS			
AP Trx #: 105383					
			Invoice: KIM CATHRYN Ref#: 69606 (FLOWERS FOR ROBERT LACOCK)		
DONATED FUND EXPENDITURES			440-5890-580600	152.14	
Vnd: MISCCC Invoice: KIM CATHRYN			440-0000-211000		152.14
Expected Check Run: 03/26/2025				<u>152.14</u>	<u>152.14</u>
03/18/2025	AP	IIMC			
AP Trx #: 105384					
			Invoice: DYKSTRA DIANA Ref#: 69599 (IIMC MEMBERSHIP)		
MEMBERSHIP DUES			100-5141-532400	195.00	
Vnd: MISCCC Invoice: DYKSTRA DIANA			100-0000-211000		195.00
Expected Check Run: 03/26/2025				<u>195.00</u>	<u>195.00</u>
03/18/2025	AP	LEAGUE OF WISCONSIN MUNIC			
AP Trx #: 105385					
			Invoice: KROPF LANA Ref#: 69615 (UPDATED LICENSING MANUALS- KROPF)		
TRAINING & TRAVEL			100-5142-533500	43.00	
Vnd: MISCCC Invoice: KROPF LANA			100-0000-211000		43.00
Expected Check Run: 03/26/2025				<u>43.00</u>	<u>43.00</u>
03/18/2025	AP	LEGACYHYDRA			
AP Trx #: 105386					
			Invoice: PETERSON RANDY Ref#: 69616 (TIGER MOWER HYDRAULIC PUMP)		
REPAIRS & MAINTENANCE			100-5324-539500	1,317.25	
Vnd: MISCCC Invoice: PETERSON RANDY			100-0000-211000		1,317.25
Expected Check Run: 03/26/2025				<u>1,317.25</u>	<u>1,317.25</u>
03/18/2025	AP	LOCAL GOVERNMENT EDUCATIO			
AP Trx #: 105387					
			Invoice: DOHERTY DIANA Ref#: 69596 (WGFOA ANNUAL MEMBERSHIP)		
MEMBERSHIP DUES			100-5145-532400	25.00	
Vnd: MISCCC Invoice: DOHERTY DIANA			100-0000-211000		25.00
Expected Check Run: 03/26/2025				<u>25.00</u>	<u>25.00</u>
03/18/2025	AP	MAILCHIMP			
AP Trx #: 105388					
			Invoice: DYKSTRA DIANA Ref#: 69601 (WEEKLY WRAP UP SUBSCRIPTION)		
OPERATIONAL SUPPLIES			100-5141-531100	47.25	
Vnd: MISCCC Invoice: DYKSTRA DIANA			100-0000-211000		47.25
Expected Check Run: 03/26/2025				<u>47.25</u>	<u>47.25</u>

Post Date	Journal	Description	GL Number	DR Amount	CR Amount
03/18/2025	AP	MARRIOTT MADISON WEST			
AP Trx #: 105389					
		CONFERENCE HOTEL	100-5141-533500	278.00	
		Vnd: MISCCC Invoice: DYKSTRA DIANA	100-0000-211000		278.00
		Expected Check Run: 03/26/2025			
				<u>278.00</u>	<u>278.00</u>
03/18/2025	AP	METRO MARKET #384			
AP Trx #: 105390					
		PROGRAMMING	440-5511-533100	25.00	
		Vnd: MISCCC Invoice: PRIDE JAMES	440-0000-211000		25.00
		Expected Check Run: 03/26/2025			
				<u>25.00</u>	<u>25.00</u>
03/18/2025	AP	METRO MARKET #384			
AP Trx #: 105391					
		OPERATIONAL SUPPLIES	150-5221-531100	20.96	
		Vnd: MISCCC Invoice: STIEN JEFFREY R	150-0000-211000		20.96
		Expected Check Run: 03/26/2025			
				<u>20.96</u>	<u>20.96</u>
03/18/2025	AP	METRO MARKET #384			
AP Trx #: 105392					
		OPERATIONAL SUPPLIES	150-5221-531100	114.58	
		Vnd: MISCCC Invoice: STIEN JEFFREY R	150-0000-211000		114.58
		Expected Check Run: 03/26/2025			
				<u>114.58</u>	<u>114.58</u>
03/18/2025	AP	METRO MARKET #384			
AP Trx #: 105393					
		OPERATIONAL SUPPLIES	100-5144-531100	42.91	
		Vnd: MISCCC Invoice: ZERFAS SHAY	100-0000-211000		42.91
		Expected Check Run: 03/26/2025			
				<u>42.91</u>	<u>42.91</u>
03/18/2025	AP	NATIONAL REGISTRY EMT			
AP Trx #: 105394					
		TRAINING & TRAVEL	150-5233-533500	25.00	
		Vnd: MISCCC Invoice: STIEN JEFFREY R	150-0000-211000		25.00
		Expected Check Run: 03/26/2025			
				<u>25.00</u>	<u>25.00</u>

Post Date	Journal	Description	GL Number	DR Amount	CR Amount
03/18/2025	AP	NETFLIX			
AP Trx #: 105395					
		THINGERY MAINTENANCE	440-5511-531800	24.99	
		Vnd: MISCCC Invoice: KIM CATHRYN	440-0000-211000		24.99
		Expected Check Run: 03/26/2025		<u>24.99</u>	<u>24.99</u>
03/18/2025	AP	OPC MSC*SERVICE FEE 024			
AP Trx #: 105396					
		MISC GENERAL EXPENSES	610-6920-693000	5.62	
		EDUCATIONAL/TRAINING EXPENSES	620-8400-854100	5.63	
		Vnd: MISCCC Invoice: CASTLE WAYNE A	610-0000-211000		5.62
		Vnd: MISCCC Invoice: CASTLE WAYNE A	620-0000-211000		5.63
		Expected Check Run: 03/26/2025		<u>11.25</u>	<u>11.25</u>
03/18/2025	AP	OPC*WI RURAL WTR CONF			
AP Trx #: 105397					
		MISC GENERAL EXPENSES	610-6920-693000	165.00	
		EDUCATIONAL/TRAINING EXPENSES	620-8400-854100	165.00	
		Vnd: MISCCC Invoice: CASTLE WAYNE A	610-0000-211000		165.00
		Vnd: MISCCC Invoice: CASTLE WAYNE A	620-0000-211000		165.00
		Expected Check Run: 03/26/2025		<u>330.00</u>	<u>330.00</u>
03/18/2025	AP	QUALITY INNS			
AP Trx #: 105398					
		MISC GENERAL EXPENSES	610-6920-693000	146.25	
		EDUCATIONAL/TRAINING EXPENSES	620-8400-854100	146.25	
		Vnd: MISCCC Invoice: KINDER MATTHEW	610-0000-211000		146.25
		Vnd: MISCCC Invoice: KINDER MATTHEW	620-0000-211000		146.25
		Expected Check Run: 03/26/2025		<u>292.50</u>	<u>292.50</u>
03/18/2025	AP	REAR VIEW SAFETY INC.			
AP Trx #: 105399					
		OPERATIONAL SUPPLIES	150-5222-531100	337.07	
		Vnd: MISCCC Invoice: STIEN JEFFREY R	150-0000-211000		337.07
		Expected Check Run: 03/26/2025		<u>337.07</u>	<u>337.07</u>
03/18/2025	AP	SPELLMAN TRAILERS			
AP Trx #: 105400					
		OPERATION SUPPLY/EXPENSE	620-8010-827000	619.10	
		Vnd: MISCCC Invoice: KINDER MATTHEW	620-0000-211000		619.10
		Expected Check Run: 03/26/2025		<u>619.10</u>	<u>619.10</u>

Post Date	Journal	Description	GL Number	DR Amount	CR Amount
03/18/2025	AP	SQ *BEE WELL CAFE			
AP Trx #: 105401					
		PROGRAMMING	440-5511-533100	25.00	
		Vnd: MISCCC Invoice: PRIDE JAMES	440-0000-211000		25.00
		Expected Check Run: 03/26/2025			
				<u>25.00</u>	<u>25.00</u>
03/18/2025	AP	SQ *BETTY BRINN CHILDREN'			
AP Trx #: 105402					
		DONATED FUND EXPENDITURES	440-5890-580600	335.00	
		Vnd: MISCCC Invoice: CEITHAMER EMILY	440-0000-211000		335.00
		Expected Check Run: 03/26/2025			
				<u>335.00</u>	<u>335.00</u>
03/18/2025	AP	SQ *SCHOOL DISTRICT OF WA			
AP Trx #: 105403					
		DONATED FUND EXPENDITURES	440-5890-580600	300.00	
		Vnd: MISCCC Invoice: CEITHAMER EMILY	440-0000-211000		300.00
		Expected Check Run: 03/26/2025			
				<u>300.00</u>	<u>300.00</u>
03/18/2025	AP	SQSP* INV170895952			
AP Trx #: 105404					
		OPERATIONAL SUPPLIES	100-5521-531100	276.00	
		Vnd: MISCCC Invoice: BITTNER RONALD	100-0000-211000		276.00
		Expected Check Run: 03/26/2025			
				<u>276.00</u>	<u>276.00</u>
03/18/2025	AP	THE HOME DEPOT #4921			
AP Trx #: 105405					
		OFFICE SUPPLIES & EXPENSES	610-6920-692100	119.39	
		OFFICE SUPPLIES & EXPENSES	620-8400-851000	119.40	
		Vnd: MISCCC Invoice: CASTLE WAYNE A	610-0000-211000		119.39
		Vnd: MISCCC Invoice: CASTLE WAYNE A	620-0000-211000		119.40
		Expected Check Run: 03/26/2025			
				<u>238.79</u>	<u>238.79</u>
03/18/2025	AP	THRIFT BOOKS GLOBAL, LLC			
AP Trx #: 105406					
		BOOKS	440-5700-532800	293.94	
		Vnd: MISCCC Invoice: CEITHAMER EMILY	440-0000-211000		293.94
		Expected Check Run: 03/26/2025			
				<u>293.94</u>	<u>293.94</u>

Post Date	Journal	Description	GL Number	DR Amount	CR Amount
03/18/2025	AP	TLF*THE FLOWER GALLERY			
AP Trx #: 105407					
		OTHER	100-5142-539900	77.00	
		Vnd: MISCCC Invoice: ZERFAS SHAY	100-0000-211000		77.00
		Expected Check Run: 03/26/2025		<u>77.00</u>	<u>77.00</u>
03/18/2025	AP	US BANK STATEMENT CREDITS			
AP Trx #: 105408					
		BOOKS	440-5700-532800		22.34
		Vnd: 3384 Invoice: CEITHAMER EMILY	440-0000-211000	22.34	
		Expected Check Run: 03/26/2025		<u>22.34</u>	<u>22.34</u>
03/18/2025	AP	US BANK STATEMENT CREDITS			
AP Trx #: 105409					
		PROGRAMMING	440-5511-533100		11.83
		Vnd: 3384 Invoice: PRIDE JAMES	440-0000-211000	11.83	
		Expected Check Run: 03/26/2025		<u>11.83</u>	<u>11.83</u>
03/18/2025	AP	UW LOCAL GOV EDUCATION			
AP Trx #: 105410					
		TRAINING & TRAVEL	100-5142-533500	20.00	
		Vnd: MISCCC Invoice: ZERFAS SHAY	100-0000-211000		20.00
		Expected Check Run: 03/26/2025		<u>20.00</u>	<u>20.00</u>
03/18/2025	AP	UW LOCAL GOV EDUCATION			
AP Trx #: 105411					
		TRAINING & TRAVEL	100-5142-533500	20.00	
		Vnd: MISCCC Invoice: ZERFAS SHAY	100-0000-211000		20.00
		Expected Check Run: 03/26/2025		<u>20.00</u>	<u>20.00</u>

Post Date	Journal	Description	GL Number	DR Amount	CR Amount
03/18/2025	AP	VBS*VONAGE BUSINESS	Invoice: DOHERTY DIANA Ref#: 69598 (VONAGE PHONE BILL 3-11 THRU 4-10)		
AP Trx #: 105412		TELEPHONE	100-5141-522500	79.10	
		TELEPHONE	100-5142-522500	79.35	
		SOFTWARE SUPPORT/MAINTENANCE	100-5145-522900	79.09	
		TELEPHONE	100-5241-522500	59.33	
		TELEPHONE	100-5323-522500	59.58	
		TELEPHONE	100-5512-522500	19.78	
		TELEPHONE	100-5120-522500	19.78	
		TELEPHONE	100-5211-522500	350.40	
		TELEPHONE	150-5221-522500	361.21	
		TELEPHONE	440-5511-522500	403.30	
		OFFICE SUPPLIES & EXPENSES	610-6920-692100	61.95	
		OFFICE SUPPLIES & EXPENSES	620-8400-851000	61.95	
		Vnd: MISCCC Invoice: DOHERTY DIANA	100-0000-211000		746.41
		Vnd: MISCCC Invoice: DOHERTY DIANA	150-0000-211000		361.21
		Vnd: MISCCC Invoice: DOHERTY DIANA	440-0000-211000		403.30
		Vnd: MISCCC Invoice: DOHERTY DIANA	610-0000-211000		61.95
		Vnd: MISCCC Invoice: DOHERTY DIANA	620-0000-211000		61.95
		Expected Check Run: 03/26/2025		1,634.82	1,634.82
03/18/2025	AP	WAL-MART #1571	Invoice: CEITHAMER EMILY Ref#: 69586 (YOUTH PROGRAM SUPPLIES)		
AP Trx #: 105413		PROGRAMMING	440-5511-533100	44.29	
		Vnd: MISCCC Invoice: CEITHAMER EMILY	440-0000-211000		44.29
		Expected Check Run: 03/26/2025		44.29	44.29
03/18/2025	AP	WAL-MART #1571	Invoice: KIM CATHRYN Ref#: 69604 (GENERAL SUPPLIES)		
AP Trx #: 105414		OPERATIONAL SUPPLIES	440-5511-531100	34.81	
		Vnd: MISCCC Invoice: KIM CATHRYN	440-0000-211000		34.81
		Expected Check Run: 03/26/2025		34.81	34.81
03/18/2025	AP	WAL-MART #1571	Invoice: SMITH JAMES A Ref#: 69626 (OFFICE/LAB SUPPLIES)		
AP Trx #: 105415		LABORATORY	620-8010-826000	9.33	
		OFFICE SUPPLIES & EXPENSES	610-6920-692100	13.56	
		OFFICE SUPPLIES & EXPENSES	620-8400-851000	13.56	
		Vnd: MISCCC Invoice: SMITH JAMES A	620-0000-211000		22.89
		Vnd: MISCCC Invoice: SMITH JAMES A	610-0000-211000		13.56
		Expected Check Run: 03/26/2025		36.45	36.45

Post Date	Journal	Description	GL Number	DR Amount	CR Amount
03/18/2025	AP	WAL-MART #1571			
AP Trx #: 105416					
		OPERATIONAL SUPPLIES	150-5221-531100	0.27	
		Vnd: MISCCC Invoice: STIEN JEFFREY R	150-0000-211000		0.27
		Expected Check Run: 03/26/2025		<u>0.27</u>	<u>0.27</u>
03/18/2025	AP	WAL-MART #1571			
AP Trx #: 105417					
		OFFICE SUPPLIES & EXPENSES	610-6920-692100	21.98	
		OFFICE SUPPLIES & EXPENSES	620-8400-851000	21.98	
		Vnd: MISCCC Invoice: SUKOWATY JAYME	610-0000-211000		21.98
		Vnd: MISCCC Invoice: SUKOWATY JAYME	620-0000-211000		21.98
		Expected Check Run: 03/26/2025		<u>43.96</u>	<u>43.96</u>
03/18/2025	AP	WISCONSIN LIBRARY ASSOCIA			
AP Trx #: 105418					
		TRAINING & TRAVEL	440-5511-533500	249.00	
		Vnd: MISCCC Invoice: ARMOUR ABBY	440-0000-211000		249.00
		Expected Check Run: 03/26/2025		<u>249.00</u>	<u>249.00</u>
03/18/2025	AP	WISCONSIN WASTEWATER OPER			
AP Trx #: 105419					
		EDUCATIONAL/TRAINING EXPENSES	620-8400-854100	93.15	
		Vnd: MISCCC Invoice: BROWN DAVID	620-0000-211000		93.15
		Expected Check Run: 03/26/2025		<u>93.15</u>	<u>93.15</u>
03/18/2025	AP	WM SUPERCENTER #1571			
AP Trx #: 105420					
		MISC GENERAL EXPENSES	610-6920-693000	19.62	
		MISC GENERAL EXPENSE	620-8400-856000	19.62	
		OFFICE SUPPLIES & EXPENSES	610-6920-692100	86.60	
		OFFICE SUPPLIES & EXPENSES	620-8400-851000	86.60	
		Vnd: MISCCC Invoice: CASTLE WAYNE A	610-0000-211000		106.22
		Vnd: MISCCC Invoice: CASTLE WAYNE A	620-0000-211000		106.22
		Expected Check Run: 03/26/2025		<u>212.44</u>	<u>212.44</u>
03/18/2025	AP	WM SUPERCENTER #1571			
AP Trx #: 105421					
		PROGRAMMING	440-5511-533100	43.68	
		Vnd: MISCCC Invoice: CEITHAMER EMILY	440-0000-211000		43.68
		Expected Check Run: 03/26/2025		<u>43.68</u>	<u>43.6</u>

Post Date	Journal	Description	GL Number	DR Amount	CR Amount
03/18/2025	AP	WM SUPERCENTER #1571	Invoice: DYKSTRA DIANA Ref#: 69603 (KEN MILLER RETIREMENT)		
AP Trx #: 105422		MISC GENERAL EXPENSES	610-6920-693000	32.23	
		MISC GENERAL EXPENSE	620-8400-856000	32.22	
		Vnd: MISCCC Invoice: DYKSTRA DIANA	610-0000-211000		32.23
		Vnd: MISCCC Invoice: DYKSTRA DIANA	620-0000-211000		32.22
		Expected Check Run: 03/26/2025		<u>64.45</u>	<u>64.45</u>
03/18/2025	AP	WM SUPERCENTER #1571	Invoice: KIM CATHRYN Ref#: 69607 (GENERAL SUPPLIES)		
AP Trx #: 105423		OPERATIONAL SUPPLIES	440-5511-531100	59.31	
		Vnd: MISCCC Invoice: KIM CATHRYN	440-0000-211000		59.31
		Expected Check Run: 03/26/2025		<u>59.31</u>	<u>59.31</u>
03/18/2025	AP	WM SUPERCENTER #1571	Invoice: KREISER ROBERT Ref#: 69613 (STAFF PHOTO)		
AP Trx #: 105424		OPERATIONAL SUPPLIES	100-5211-531100	1.09	
		Vnd: MISCCC Invoice: KREISER ROBERT	100-0000-211000		1.09
		Expected Check Run: 03/26/2025		<u>1.09</u>	<u>1.09</u>
03/18/2025	AP	WM SUPERCENTER #1571	Invoice: SMITH JAMES A Ref#: 69624 (OFFICE SUPPLIES)		
AP Trx #: 105425		OFFICE SUPPLIES & EXPENSES	610-6920-692100	17.15	
		OFFICE SUPPLIES & EXPENSES	620-8400-851000	17.15	
		Vnd: MISCCC Invoice: SMITH JAMES A	610-0000-211000		17.15
		Vnd: MISCCC Invoice: SMITH JAMES A	620-0000-211000		17.15
		Expected Check Run: 03/26/2025		<u>34.30</u>	<u>34.30</u>
03/18/2025	AP	WM SUPERCENTER #1571	Invoice: SMITH JAMES A Ref#: 69625 (LAB SUPPLIES)		
AP Trx #: 105426		LABORATORY	620-8010-826000	9.32	
		Vnd: MISCCC Invoice: SMITH JAMES A	620-0000-211000		9.32
		Expected Check Run: 03/26/2025		<u>9.32</u>	<u>9.32</u>
03/18/2025	AP	WM SUPERCENTER #1571	Invoice: SMITH JAMES A Ref#: 69627 (KEN MILLER RETIREMENT)		
AP Trx #: 105427		MISC GENERAL EXPENSES	610-6920-693000	11.45	
		MISC GENERAL EXPENSE	620-8400-856000	11.45	
		Vnd: MISCCC Invoice: SMITH JAMES A	610-0000-211000		11.45
		Vnd: MISCCC Invoice: SMITH JAMES A	620-0000-211000		11.45
		Expected Check Run: 03/26/2025		<u>22.90</u>	<u>22.90</u>

Post Date	Journal	Description	GL Number	DR Amount	CR Amount
03/18/2025	AP	WM SUPERCENTER #1571			
AP Trx #: 105428					
		OPERATIONAL SUPPLIES	150-5221-531100	0.98	
		Vnd: MISCCC Invoice: STIEN JEFFREY R	150-0000-211000		0.98
		Expected Check Run: 03/26/2025		<u>0.98</u>	<u>0.98</u>
03/18/2025	AP	WMCA			
AP Trx #: 105429					
		MEMBERSHIP DUES	100-5141-532400	65.00	
		Vnd: MISCCC Invoice: DYKSTRA DIANA	100-0000-211000		65.00
		Expected Check Run: 03/26/2025		<u>65.00</u>	<u>65.00</u>
03/18/2025	AP	WMCA			
AP Trx #: 105430					
		MEMBERSHIP DUES	100-5142-532400	65.00	
		Vnd: MISCCC Invoice: ZERFAS SHAY	100-0000-211000		65.00
		Expected Check Run: 03/26/2025		<u>65.00</u>	<u>65.00</u>
03/18/2025	AP	WVOA			
AP Trx #: 105431					
		EDUCATIONAL/TRAINING EXPENSES	620-8400-854100	93.15	
		Vnd: MISCCC Invoice: SUKOWATY JAYME	620-0000-211000		93.15
		Expected Check Run: 03/26/2025		<u>93.15</u>	<u>93.15</u>
03/18/2025	AP	WWW.BESTOFSIGNS.COM			
AP Trx #: 105432					
		OUTREACH	440-5511-533300	190.09	
		Vnd: MISCCC Invoice: PRIDE JAMES	440-0000-211000		190.09
		Expected Check Run: 03/26/2025		<u>190.09</u>	<u>190.09</u>
03/18/2025	AP	WWW.BESTOFSIGNS.COM			
AP Trx #: 105433					
		OUTREACH	440-5511-533300	38.46	
		Vnd: MISCCC Invoice: PRIDE JAMES	440-0000-211000		38.46
		Expected Check Run: 03/26/2025		<u>38.46</u>	<u>38.46</u>

User: BKEIZER

BANK CODE: GEN PAY BY: EFT TRANSFER CHECK RUN DATES 03/26/2025 - 03/26/2025

DB: Mukwonago

Post Date	Journal	Description	GL Number	DR Amount	CR Amount
03/18/2025	AP	WWW.UI.COM	Invoice: BITTNER RONALD Ref#: 69574 (SECURITY UPGRADES)		
AP Trx #: 105434		IMPROVEMENTS	100-5160-582100	159.00	
		IMPROVEMENTS	100-5512-582100	129.00	
		OPERATIONAL SUPPLIES	100-5521-531100	522.80	
		Vnd: MISCCC Invoice: BITTNER RONALD	100-0000-211000		810.80
		Expected Check Run: 03/26/2025			
				810.80	810.80
03/18/2025	AP	WWW.UI.COM	Invoice: CASTLE WAYNE A Ref#: 69583 (NETWORK ACCESS POINTS)		
AP Trx #: 105435		OPERATION SUPPLY/EXP-PUMPING	610-6210-662300	332.80	
		Vnd: MISCCC Invoice: CASTLE WAYNE A	610-0000-211000		332.80
		Expected Check Run: 03/26/2025			
				332.80	332.80
				12,561.01	12,561.01
Cash/Payable Account Totals:					
		VOUCHERS PAYABLE	100-0000-211000		4,938.51
		VOUCHERS PAYABLE	150-0000-211000		1,010.51
		VOUCHERS PAYABLE	440-0000-211000		2,616.40
		VOUCHERS PAYABLE	610-0000-211000		1,561.45
		VOUCHERS PAYABLE	620-0000-211000		2,365.80
		TOTAL INCREASE IN PAYABI			12,492.67

Post Date	Journal	Description	GL Number	DR Amount	CR Amount
03/25/2025	AP	DELTA DENTAL OF WISCONSIN	Invoice: MAR 2025 Ref#: 69738 (APRIL 2025 DENTAL PREMIUMS)		
AP Trx #: 105339					
		APRIL 2025 DENTAL PREMIUMS	100-0000-215304	2,724.59	
		APRIL 2025 DENTAL PREMIUMS	440-0000-215304	216.18	
		APRIL 2025 DENTAL PREMIUMS	150-0000-215304	406.79	
		APRIL 2025 DENTAL PREMIUMS	610-0000-215304	109.65	
		APRIL 2025 DENTAL PREMIUMS	620-0000-215304	269.63	
		Vnd: 2974 Invoice: MAR 2025	100-0000-211000		2,724.59
		Vnd: 2974 Invoice: MAR 2025	440-0000-211000		216.18
		Vnd: 2974 Invoice: MAR 2025	150-0000-211000		406.79
		Vnd: 2974 Invoice: MAR 2025	610-0000-211000		109.65
		Vnd: 2974 Invoice: MAR 2025	620-0000-211000		269.63
		Expected Check Run: 03/25/2025		<u>3,726.84</u>	<u>3,726.84</u>
03/25/2025	AP	DELTA DENTAL OF WISCONSIN	Invoice: MAR 2025 V Ref#: 69739 (APR 2025 VISION PREMIUMS)		
AP Trx #: 105340					
		APR 2025 VISION PREMIUMS	100-0000-215303	131.70	
		APR 2025 VISION PREMIUMS	440-0000-215303	30.40	
		APR 2025 VISION PREMIUMS	150-0000-215303	30.02	
		APR 2025 VISION PREMIUMS	610-0000-215303	11.42	
		APR 2025 VISION PREMIUMS	620-0000-215303	41.16	
		Vnd: 2974 Invoice: MAR 2025 V	100-0000-211000		131.70
		Vnd: 2974 Invoice: MAR 2025 V	440-0000-211000		30.40
		Vnd: 2974 Invoice: MAR 2025 V	150-0000-211000		30.02
		Vnd: 2974 Invoice: MAR 2025 V	610-0000-211000		11.42
		Vnd: 2974 Invoice: MAR 2025 V	620-0000-211000		41.16
		Expected Check Run: 03/25/2025		<u>244.70</u>	<u>244.70</u>
03/25/2025	AP	EMPLOYEE TRUST FUNDS	Invoice: MARCH 2025 Ref#: 69735 (APRIL 2025 HEALTH INSURANCE)		
AP Trx #: 105341					
		APRIL 2025 HEALTH INSURANCE	100-0000-215300	68,373.35	
		APRIL 2025 HEALTH INSURANCE	150-0000-215300	19,570.78	
		APRIL 2025 HEALTH INSURANCE	440-0000-215300	5,938.03	
		APRIL 2025 HEALTH INSURANCE	610-0000-215300	6,362.81	
		APRIL 2025 HEALTH INSURANCE	620-0000-215300	9,636.23	
		WENDLANDT PREM TO COLLECT APRIL 2025	620-0000-215300	436.80	
		Vnd: 0008 Invoice: MARCH 2025	100-0000-211000		68,373.35
		Vnd: 0008 Invoice: MARCH 2025	150-0000-211000		19,570.78
		Vnd: 0008 Invoice: MARCH 2025	440-0000-211000		5,938.03
		Vnd: 0008 Invoice: MARCH 2025	610-0000-211000		6,362.81
		Vnd: 0008 Invoice: MARCH 2025	620-0000-211000		10,073.03
		Expected Check Run: 03/25/2025		<u>110,318.00</u>	<u>110,318.00</u>

Post Date	Journal	Description	GL Number	DR Amount	CR Amount
03/25/2025	AP	GREAT WEST RETIREMENT SERVICES	Invoice: PR 032825 Ref#: 69747 (RETIREMENT SAVINGS 03-28-25 PR)		
AP Trx #: 105342		GW / WI DEF COMP PR 03/28/25	100-0000-215250	794.42	
		GW / WI DEF COMP PR 03/28/25	150-0000-215250	2,751.62	
		Vnd: 0005 Invoice: PR 032825	100-0000-211000		794.42
		Vnd: 0005 Invoice: PR 032825	150-0000-211000		2,751.62
		Expected Check Run: 03/25/2025		<u>3,546.04</u>	<u>3,546.04</u>
03/25/2025	AP	MISSION SQUARE	Invoice: PR032825 Ref#: 69745 (RETIREMENT SAVINGS 03-28-25 PR 305155 -)		
AP Trx #: 105343		DEF COMP 03-28-25 PR 305155 - 6775105	100-0000-215250	3,827.02	
		DEF COMP 03-28-25 PR 305155 - 6775105	150-0000-215250	57.19	
		DEF COMP 03-28-25 PR 305155 - 6775105	440-0000-215250	1,012.30	
		DEF COMP 03-28-25 PR 305155 - 6775105	610-0000-215250	197.46	
		DEF COMP 03-28-25 PR 305155 - 6775105	620-0000-215250	262.89	
		Vnd: 0010 Invoice: PR032825	100-0000-211000		3,827.02
		Vnd: 0010 Invoice: PR032825	150-0000-211000		57.19
		Vnd: 0010 Invoice: PR032825	440-0000-211000		1,012.30
		Vnd: 0010 Invoice: PR032825	610-0000-211000		197.46
		Vnd: 0010 Invoice: PR032825	620-0000-211000		262.89
		Expected Check Run: 03/25/2025		<u>5,356.86</u>	<u>5,356.86</u>
03/25/2025	AP	TASC	Invoice: IN3405034 Ref#: 69741 (FLEX ADMIN 04/01/25-06/30/25)		
AP Trx #: 105344		FLEX ADMIN 04/01/25-06/30/25	100-5241-539900	36.12	
		FLEX ADMIN 04/01/25-06/30/25	100-5211-539900	216.72	
		FLEX ADMIN 04/01/25-06/30/25	100-5212-539900	162.54	
		FLEX ADMIN 04/01/25-06/30/25	100-5212-539900	36.12	
		FLEX ADMIN 04/01/25-06/30/25	100-5142-539900	36.12	
		FLEX ADMIN 04/01/25-06/30/25	100-5323-531100	144.48	
		FLEX ADMIN 04/01/25-06/30/25	150-5221-539900	144.48	
		FLEX ADMIN 04/01/25-06/30/25	440-5511-515900	162.54	
		FLEX ADMIN 04/01/25-06/30/25	610-6920-693000	72.24	
		FLEX ADMIN 04/01/25-06/30/25	620-8300-840000	54.18	
		FLEX ADMIN 04/01/25-06/30/25	100-5141-539900	36.12	
		FLEX ADMIN 04/01/25-06/30/25	100-5145-539900	108.36	
		FLEX ADMIN 04/01/25-06/30/25	100-5632-539900	18.06	
		FLEX ADMIN 04/01/25-06/30/25	150-5233-531100	108.36	
		Vnd: 2374 Invoice: IN3405034	100-0000-211000		794.64
		Vnd: 2374 Invoice: IN3405034	150-0000-211000		252.84
		Vnd: 2374 Invoice: IN3405034	440-0000-211000		162.54
		Vnd: 2374 Invoice: IN3405034	610-0000-211000		72.24
		Vnd: 2374 Invoice: IN3405034	620-0000-211000		54.18
		Expected Check Run: 03/25/2025		<u>1,336.44</u>	<u>1,336.44</u>

Post Date	Journal	Description	GL Number	DR Amount	CR Amount
-----------	---------	-------------	-----------	-----------	-----------

03/25/2025	AP	UKG INC.	Invoice: 300181359 Ref#: 69737(PAYROLL PROCESSING FEES FEB 2025)		
AP Trx #: 105345					
		PAYROLL PROCESSING FEES FEB 2025	100-5300-539900	112.44	
		PAYROLL PROCESSING FEES FEB 2025	100-5111-539900	98.39	
		PAYROLL PROCESSING FEES FEB 2025	100-5120-539900	28.11	
		PAYROLL PROCESSING FEES FEB 2025	100-5141-539900	14.06	
		PAYROLL PROCESSING FEES FEB 2025	100-5145-539900	56.20	
		PAYROLL PROCESSING FEES FEB 2025	100-5142-539900	28.11	
		PAYROLL PROCESSING FEES FEB 2025	100-5144-521900	168.67	
		PAYROLL PROCESSING FEES FEB 2025	100-5241-539900	28.11	
		PAYROLL PROCESSING FEES FEB 2025	100-5670-521900	14.06	
		PAYROLL PROCESSING FEES FEB 2025	100-5211-539900	140.56	
		PAYROLL PROCESSING FEES FEB 2025	100-5212-539900	140.56	
		PAYROLL PROCESSING FEES FEB 2025	100-5213-521900	28.11	
		PAYROLL PROCESSING FEES FEB 2025	150-5221-539900	393.56	
		PAYROLL PROCESSING FEES FEB 2025	150-5233-531100	84.33	
		PAYROLL PROCESSING FEES FEB 2025	440-5511-534000	393.56	
		PAYROLL PROCESSING FEES FEB 2025	610-6902-690300	56.22	
		PAYROLL PROCESSING FEES FEB 2025	620-8300-840000	42.17	
		Vnd: 3181 Invoice: 300181359	100-0000-211000		857.38
		Vnd: 3181 Invoice: 300181359	150-0000-211000		477.89
		Vnd: 3181 Invoice: 300181359	440-0000-211000		393.56
		Vnd: 3181 Invoice: 300181359	610-0000-211000		56.22
		Vnd: 3181 Invoice: 300181359	620-0000-211000		42.17
		Expected Check Run: 03/25/2025			
				1,827.22	1,827.22

03/25/2025	AP	WI RETIREMENT SYSTEM	Invoice: MAR 2025 Ref#: 69736(WISCONSIN RETIREMENT CONTRIBUTIONS - FEB)		
AP Trx #: 105346					
		WRS FEB 2025 CONTRIBUTIONS	100-0000-215200	39,727.55	
		WRS FEB 2025 CONTRIBUTIONS	150-0000-215200	19,047.64	
		WRS FEB 2025 CONTRIBUTIONS	440-0000-215200	6,324.70	
		WRS FEB 2025 CONTRIBUTIONS	500-0000-215200	15.04	
		WRS FEB 2025 CONTRIBUTIONS	610-0000-215200	2,330.28	
		WRS FEB 2025 CONTRIBUTIONS	620-0000-215200	2,902.36	
		ADJ	100-0000-215200	0.06	
		Vnd: 0019 Invoice: MAR 2025	100-0000-211000		39,727.61
		Vnd: 0019 Invoice: MAR 2025	150-0000-211000		19,047.64
		Vnd: 0019 Invoice: MAR 2025	440-0000-211000		6,324.70
		Vnd: 0019 Invoice: MAR 2025	500-0000-211000		15.04
		Vnd: 0019 Invoice: MAR 2025	610-0000-211000		2,330.28
		Vnd: 0019 Invoice: MAR 2025	620-0000-211000		2,902.36
		Expected Check Run: 03/25/2025			
				70,347.63	70,347.63
				196,703.73	196,703.73

Cash/Payable Account Totals:

VOUCHERS PAYABLE	100-0000-211000	117,230.71
VOUCHERS PAYABLE	150-0000-211000	42,594.77
VOUCHERS PAYABLE	440-0000-211000	14,077.71
VOUCHERS PAYABLE	500-0000-211000	15.04
VOUCHERS PAYABLE	610-0000-211000	9,140.00

Post Date	Journal	Description	GL Number	DR Amount	CR Amount
		VOUCHERS PAYABLE	620-0000-211000		13,645.42
			TOTAL INCREASE IN PAYABI		196,703.73

PERIOD ENDING 02/28/2025

SELECT FUNDS

GL NUMBER	DESCRIPTION	2025 AMENDED BUDGET	YTD BALANCE 02/28/2025	AVAILABLE BALANCE	% BDGT USED
Fund 100 - GENERAL FUND					
Revenues					
OTHERREV	OTHER REVENUES	235,000.00	8,349.90	226,650.10	3.55
OFS	OTHER FINANCING SOURCES	18,250.00	0.00	18,250.00	0.00
PTAX	GENERAL PROPERTY TAX	3,264,504.00	2,544,322.78	720,181.22	77.94
TAXES	OTHER TAXES	400,500.00	64,905.47	335,594.53	16.21
IGOVTRV	INTERGOVERNMENTAL REVENUES	1,130,909.00	141,999.27	988,909.73	12.56
LICPER	LICENSES & PERMITS	427,373.00	65,366.63	362,006.37	15.29
LAWORD	FINES & FORFEITURES	145,000.00	29,070.13	115,929.87	20.05
PUBCHGS	PUBLIC CHARGES FOR SERVICES	18,698.00	2,993.40	15,704.60	16.01
LEISURE	LEISURE ACTIVITIES	72,000.00	0.00	72,000.00	0.00
IGOVTCH	INTERGOVERNMENTAL CHARGES	205,100.00	12,139.06	192,960.94	5.92
INVTINC	INVESTMENT INCOME	262,228.00	81,112.30	181,115.70	30.93
TOTAL REVENUES		6,179,562.00	2,950,258.94	3,229,303.06	47.74
Expenditures					
5111	VILLAGE BOARD	72,363.00	12,228.69	60,134.31	16.90
5112	HISTORIC PRESERVATION	290.00	0.00	290.00	0.00
5120	MUNICIPAL COURT	40,322.00	12,772.37	27,549.63	31.68
5130	VILLAGE ATTORNEY	108,750.00	2,857.50	105,892.50	2.63
5141	VILLAGE ADMINISTRATOR	222,341.00	29,528.00	192,813.00	13.28
5142	CLERK-TREASURER	265,331.00	27,737.86	237,593.14	10.45
5144	ELECTIONS	31,650.00	3,362.91	28,287.09	10.63
5145	FINANCE DEPARTMENT	88,397.00	61,313.95	27,083.05	69.36
5150	IT SERVICES	15,000.00	30.00	14,970.00	0.20
5151	INDEPENDENT AUDITING	15,000.00	0.00	15,000.00	0.00
5153	ASSESSMENT OF PROPERTY	36,200.00	5,978.36	30,221.64	16.51
5154	RISK & PROPERTY INSURANCE	136,300.00	28,407.14	107,892.86	20.84
5160	VILLAGE HALL	55,638.00	7,428.40	48,209.60	13.35
5211	POLICE ADMINISTRATION	1,414,158.00	224,030.34	1,190,127.66	15.84
5212	POLICE PATROL	1,267,853.00	191,331.30	1,076,521.70	15.09
5213	CRIME INVESTIGATION	279,521.00	43,101.54	236,419.46	15.42
5215	POLICE TRAINING	9,000.00	806.74	8,193.26	8.96
5220	FIRE STATION (VILLAGE)	9,705.00	2,046.87	7,658.13	21.09
5235	EMERGENCY GOVERNMENT	2,000.00	0.00	2,000.00	0.00
5241	BUILDING INSPECTOR	339,312.00	43,241.59	296,070.41	12.74
5247	BOARD OF APPEALS	900.00	0.00	900.00	0.00
5254	DAMS	12,823.00	1,339.78	11,483.22	10.45
5300	DPW GENERAL ADMINISTRATION	418,931.00	73,323.55	345,607.45	17.50
5323	GARAGE	78,464.00	20,292.77	58,171.23	25.86
5324	MACHINERY & EQUIPMENT	134,480.00	13,767.37	120,712.63	10.24
5335	ENGINEERING	75,000.00	5,333.34	69,666.66	7.11
5341	STREETS & ALLEYS	12,993.00	1,242.00	11,751.00	9.56
5342	STREET LIGHTING	179,250.00	15,033.47	164,216.53	8.39
5343	CURBS GUTTERS & SIDEWALKS	2,694.00	0.00	2,694.00	0.00
5344	STORM SEWER	13,972.00	193.76	13,778.24	1.39
5345	STREET CLEANING	23,309.00	484.70	22,824.30	2.08
5346	BRIDGES & CULVERTS	500.00	0.00	500.00	0.00
5347	SNOW & ICE CONTROL	93,150.00	18,602.42	74,547.58	19.97
5348	STREET SIGNS & MARKINGS	21,663.00	0.00	21,663.00	0.00
5362	GARBAGE COLLECTION	7,189.00	419.80	6,769.20	5.84
5431	ANIMAL POUND	2,500.00	0.00	2,500.00	0.00
5512	MUSEUM	10,750.00	834.58	9,915.42	7.76
5521	PARKS	208,919.00	2,663.57	206,255.43	1.27
5522	CELEBRATIONS	8,118.00	855.37	7,262.63	10.54
5611	FORESTRY	40,889.00	5,815.58	35,073.42	14.22
5613	WEED CONTROL	542.00	0.00	542.00	0.00
5632	PLANNING DEPARTMENT	129,250.00	570.93	128,679.07	0.44
5660	STORMWATER MASTER PLAN	19,250.00	386.54	18,863.46	2.01
5670	ECONOMIC DEVELOPMENT	42,895.00	3,852.67	39,042.33	8.98
5900	OTHER FINANCING USES	232,000.00	0.00	232,000.00	0.00
TOTAL EXPENDITURES		6,179,562.00	861,215.76	5,318,346.24	13.94
Fund 100 - GENERAL FUND:					
TOTAL REVENUES		6,179,562.00	2,950,258.94	3,229,303.06	47.74
TOTAL EXPENDITURES		6,179,562.00	861,215.76	5,318,346.24	13.94
NET OF REVENUES & EXPENDITURES		0.00	2,089,043.18	(2,089,043.18)	100.00

PERIOD ENDING 02/28/2025

SELECT FUNDS

GL NUMBER	DESCRIPTION	2025 AMENDED BUDGET	YTD BALANCE 02/28/2025	AVAILABLE BALANCE	% BDGT USED
Fund 150 - FIRE/AMBULANCE FUND					
Revenues					
OTHERREV	OTHER REVENUES	0.00	44.40	(44.40)	100.00
PTAX	GENERAL PROPERTY TAX	613,110.00	102,185.00	510,925.00	16.67
EBIX	EBIX REVENUES	1,303,000.00	201,072.39	1,101,927.61	15.43
IGOVTRV	INTERGOVERNMENTAL REVENUES	128,000.00	0.00	128,000.00	0.00
PUBCHGS	PUBLIC CHARGES FOR SERVICES	500.00	0.00	500.00	0.00
IGOVTC	INTERGOVERNMENTAL CHARGES	613,110.00	102,185.00	510,925.00	16.67
INVSTINC	INVESTMENT INCOME	40,000.00	8,563.60	31,436.40	21.41
TOTAL REVENUES		2,697,720.00	414,050.39	2,283,669.61	15.35
Expenditures					
5140	ADMINISTRATIVE & GENERAL	29,150.00	0.00	29,150.00	0.00
5221	FIRE ADMINISTRATION	1,139,329.00	176,656.63	962,672.37	15.51
5222	FIRE SUPPRESSION	72,900.00	2,640.96	70,259.04	3.62
5223	FIRE TRAINING	29,429.00	3,809.33	25,619.67	12.94
5231	AMBULANCE	485,681.00	51,030.83	434,650.17	10.51
5232	AMBULANCE TRAINING	20,738.00	1,483.83	19,254.17	7.16
5233	REFERENDUM FUNDED STAFFING	751,579.00	113,645.34	637,933.66	15.12
5700	CAPITAL OUTLAY EXPENDITURES	80,000.00	0.00	80,000.00	0.00
5900	OTHER FINANCING USES	88,914.00	0.00	88,914.00	0.00
TOTAL EXPENDITURES		2,697,720.00	349,266.92	2,348,453.08	12.95
Fund 150 - FIRE/AMBULANCE FUND:					
TOTAL REVENUES		2,697,720.00	414,050.39	2,283,669.61	15.35
TOTAL EXPENDITURES		2,697,720.00	349,266.92	2,348,453.08	12.95
NET OF REVENUES & EXPENDITURES		0.00	64,783.47	(64,783.47)	100.00

PERIOD ENDING 02/28/2025

SELECT FUNDS

GL NUMBER	DESCRIPTION	2025 AMENDED BUDGET	YTD BALANCE 02/28/2025	AVAILABLE BALANCE	% BDGT USED
Fund 610 - WATER UTILITY FUND					
Revenues					
OTHERREV	OTHER REVENUES	200.00	0.00	200.00	0.00
UTILREV	UTILITY REVENUES	2,217,000.00	1,586.04	2,215,413.96	0.07
CONTRIB	CONTRIBUTED CAPITAL	0.00	16,697.00	(16,697.00)	100.00
MISCINC	MISC INCOME UTILITIES	162,000.00	45,920.18	116,079.82	28.35
IGOVTCH	INTERGOVERNMENTAL CHARGES	1,200.00	52.63	1,147.37	4.39
INVTINC	INVESTMENT INCOME	104,600.00	22,726.05	81,873.95	21.73
TOTAL REVENUES		2,485,000.00	86,981.90	2,398,018.10	3.50
Expenditures					
5900	OTHER FINANCING USES	80,162.00	0.00	80,162.00	0.00
6200	PUMPING OPERATIONS	154,102.00	17,722.06	136,379.94	11.50
6210	PUMPING MAINTENANCE	72,228.00	4,059.49	68,168.51	5.62
6300	WATER TREATMENT OPERATIONS	122,842.00	11,421.05	111,420.95	9.30
6310	WATER TREATMENT MAINTENANCE	23,549.00	1,002.98	22,546.02	4.26
6450	T&D-DISTR RSRVR/STNDP MAINT	4,316.00	84.53	4,231.47	1.96
6451	T&D-MAINS MAINTENANCE	60,480.00	1,323.14	59,156.86	2.19
6452	T&D-SERVICES MAINTENANCE	57,940.00	3,452.25	54,487.75	5.96
6453	T&D-METERS MAINTENANCE	38,471.00	1,313.93	37,157.07	3.42
6454	T&D-HYDRANTS MAINTENANCE	51,402.00	0.00	51,402.00	0.00
6901	METER READING LABOR	4,368.00	0.00	4,368.00	0.00
6902	ACCOUNTING & COLLECTING LABOR	87,678.00	402.75	87,275.25	0.46
6920	ADMINISTRATIVE & GENERAL EXP	1,097,872.00	135,477.18	962,394.82	12.34
TOTAL EXPENDITURES		1,855,410.00	176,259.36	1,679,150.64	9.50
Fund 610 - WATER UTILITY FUND:					
TOTAL REVENUES		2,485,000.00	86,981.90	2,398,018.10	3.50
TOTAL EXPENDITURES		1,855,410.00	176,259.36	1,679,150.64	9.50
NET OF REVENUES & EXPENDITURES		629,590.00	(89,277.46)	718,867.46	14.18

PERIOD ENDING 02/28/2025

SELECT FUNDS

GL NUMBER	DESCRIPTION	2025 AMENDED BUDGET	YTD BALANCE 02/28/2025	AVAILABLE BALANCE	% BDGT USED
Fund 620 - SEWER UTILITY FUND					
Revenues					
OTHERREV	OTHER REVENUES	400.00	0.00	400.00	0.00
OFS	OTHER FINANCING SOURCES	15,000.00	0.00	15,000.00	0.00
UTILREV	UTILITY REVENUES	2,090,000.00	3,498.37	2,086,501.63	0.17
LICPER	LICENSES & PERMITS	26,500.00	12,246.00	14,254.00	46.21
CONTRIB	CONTRIBUTED CAPITAL	12,500.00	6,171.00	6,329.00	49.37
MISCINC	MISC INCOME UTILITIES	225,000.00	39,827.39	185,172.61	17.70
INVSTINC	INVESTMENT INCOME	97,474.00	17,127.37	80,346.63	17.57
TOTAL REVENUES		2,466,874.00	78,870.13	2,388,003.87	3.20
Expenditures					
5900	OTHER FINANCING USES	133,154.00	0.00	133,154.00	0.00
8010	WWTP-TREATMENT/DISPOSAL/GP	697,277.00	70,843.87	626,433.13	10.16
8020	LIFT STATIONS/PUMPING EQUIP	31,350.00	1,910.04	29,439.96	6.09
8030	WASTEWATER COLLECTION SYSTEM	110,147.00	16,960.86	93,186.14	15.40
8300	ACCOUNTING/COLLECTING	84,678.00	792.00	83,886.00	0.94
8400	ADMINISTRATIVE & GENERAL	739,763.00	60,194.60	679,568.40	8.14
TOTAL EXPENDITURES		1,796,369.00	150,701.37	1,645,667.63	8.39
Fund 620 - SEWER UTILITY FUND:					
TOTAL REVENUES		2,466,874.00	78,870.13	2,388,003.87	3.20
TOTAL EXPENDITURES		1,796,369.00	150,701.37	1,645,667.63	8.39
NET OF REVENUES & EXPENDITURES		670,505.00	(71,831.24)	742,336.24	10.71

PERIOD ENDING 02/28/2025

SELECT FUNDS

GL NUMBER	DESCRIPTION	2025 AMENDED BUDGET	YTD BALANCE 02/28/2025	AVAILABLE BALANCE	% BDGT USED
TOTAL REVENUES - ALL FUNDS		13,829,156.00	3,530,161.36	10,298,994.64	25.53
TOTAL EXPENDITURES - ALL FUNDS		<u>12,529,061.00</u>	<u>1,537,443.41</u>	<u>10,991,617.59</u>	<u>12.27</u>
NET OF REVENUES & EXPENDITURES		1,300,095.00	1,992,717.95	(692,622.95)	153.27

TREASURERS REPORT

Feb-2025

TOTAL

Citizens

LGIP

Long Term
Investments - Johnson
Bank & ADM

GENERAL VILLAGE

100-111xxx	General Fund	4,700,668.51	1,750,368.19	980,276.71	1,970,023.61
100-111005/020/033	Checking/MRA/Accrued Sick	1,285,284.11	817,992.51	335,395.87	131,895.73
150-111300	Fire Department	1,336,652.17	387,206.12	949,446.05	
200-110xxx	Community Development (Deback)	540,341.42	14,781.75	525,559.67	
210-111xxx	Wisc Development - RLF	91,308.61	91,308.61	-	
220-111xxx	TID#3-General	937,437.24	937,437.24	-	
240-111xxx	TID#4-General	979,366.51	242,453.41	736,913.10	
250-111xxx	TID#5-General	3,291,010.54	392,368.78	2,898,641.76	
260-111xxx	TID#6-General	5,684.79	5,684.79		
300-111xxx	Debt Service	2,613,551.22	349,231.00	2,264,320.22	
320-111300	Fire Department Designated	694,528.19	327.84	44,200.35	650,000.00
340-111xxx	Village Designated Funds	909,020.50	318,302.20	590,718.30	
350-111xxx	American Rescue Plan Act	381,307.45	799.41	380,508.04	
410-111300	Recycling	377,016.49	377,016.49	-	
430-111300	Capital Equipment	331,033.54	758.67	330,274.87	
440-111xxx	Library	582,750.24	246,782.00	335,968.24	
480-111xxx	Capital Improvement Funds	1,772,534.70	555.07	1,771,979.63	
500-111300	Stormwater District #1	81,880.67	81,880.67	-	
600-111xxx	Impact Fees	260,349.35	260,349.35	-	
720-111xxx	Taxroll	379,593.01	(28,693.98)	408,286.99	
810-111xxx	Parkland Site	265,310.79	19,309.37	246,001.42	
TOTAL		21,816,630.05	6,266,219.49	12,798,491.22	2,751,919.34

WATER UTILITY

610-111300	Cash	411,678.83	411,678.83		
610-111200	Bonds & Unrestricted Cash	2,710,498.54		2,710,498.54	
610-111050	Current Year Debt Reserve	123,625.08	123,625.08	-	
610-111060	Required Debt Reserve	527,169.72	-	84,333.54	442,836.18
610-111080	Impact Fee	17,178.37	17,178.37	-	
610-111033	Accrued Sick Pay	11,130.78		11,130.78	-
TOTAL		3,801,281.32	552,482.28	2,805,962.86	442,836.18

SEWER UTILITY

620-111300	Cash	497,084.36	497,084.36		
620-111200	Bonds & Unrestricted Cash	458,985.55		458,985.55	
620-111040	Sewer Connection Fee	394,178.58	13,212.54	380,966.04	-
620-111060	Required Debt Reserve	835,757.51	-	62,382.15	773,375.36
620-111050	Current Year Debt Reserve	202,929.34	202,929.34	-	
620-111070	Equipment Replacement Fund	810,835.19	-	810,835.19	-
620-111080	Impact Fee	7,131.58	7,131.58	-	
620-111033	Accrued Sick Pay	11,130.78		11,130.78	-
TOTAL		3,218,032.89	720,357.82	1,724,299.71	773,375.36

GRAND TOTAL	28,835,944.26	7,539,059.59	17,328,753.79	3,968,130.88
--------------------	----------------------	---------------------	----------------------	---------------------

Prepared by Diana Doherty

balance check

28,835,944.26

Village of Mukwonago
440 River Crest Court
Mukwonago, WI 53149
Phone: (262) 363-6420
Fax: (262) 363-6425
www.villageofmukwonago.gov

VILLAGE OF MUKWONAGO SPECIAL EVENT PERMIT APPLICATION

Application Fee: See fee sheet

Date Submitted: 2/18/25

Total Fees Paid: \$10.00

Application must be received a minimum of 90 days prior to the special event. Fees are non-refundable.

Please refer to Special Event Manual for step by step instructions.

PAID
CK NO. _____
DATE _____

ORGANIZATION INFORMATION

Name of Organization: Clarendon Avenue Elementary School
Mailing Address: 915 Clarendon Avenue City: Mukwonago State: WI Zip: 53149

EVENT INFORMATION

Name of the Event: Art Show Date(s) of the Event: May 22, 2025
Event Start Time: 4:30 Event End Time: 6:30
Location of the Event: Clarendon Avenue

- A. Will your event take place in a residential neighborhood? *If yes, you will be required to notify all adjacent property owners when the event will occur.* YES NO
- B. Please provide your COVID-19 Action Plan.
- C. You MUST attach a detailed map/sketch of your event indicating the specific location, layout of your event, and the direction of the route, including all turns and the number of traffic lanes to be used.
- D. If you are using a Village park, you must reserve the park through the Village Clerk-Treasurer's Office prior to getting your special event permit approved by the Village Board. Call 262-363-6420 ext 2104.
- E. Briefly describe your event and its purpose.
This will be our annual Art Show and a Parent Teacher Group (PTG) Community event. We plan to use the side of the school on Clarendon Avenue where it will overflow onto the street. We will have some music playing (on school grounds) through a speaker. We plan to have a few food trucks, activities like sidewalk chalk, and possibly some small rides or inflatables. We also hope for fire/police presence.
- F. Based on the class definitions found in the manual, what class is your event? CLASS I CLASS II
- G. Estimated # of participants: ~500 Spectators: _____ Vendors: 2-3

OTHER INFORMATION

- A. Is there an outdoor bar that will serve alcohol? *If yes, temporary Class B beer and/or wine (picnic) and operator (bartender) licenses are necessary under separate application.* YES NO
- B. Please list the number of Village of Mukwonago licensed bartenders that will be on site: _____
- C. Will you be selling/serving food? *If yes, you will need to contact Waukesha County Health Department (262-896-8300) for proper permits.* YES NO
FOOD TRUCKS
- D. Will your event need electricity? *If yes, the Fire Department and Building Inspection Department will need to inspect prior to being energized.* YES NO
- E. Will you be setting up any lighting? *If yes, the Fire Department and Building Inspection Department will need to inspect prior to being energized.* YES NO
- F. Will your event require any fencing? *If yes, please provide plans for the fencing location and the gates.* YES NO
- G. Does your event involve fireworks? *If yes, you will need to contact the Fire Department (262-363-6426) for proper permits.* YES NO
- H. Does your event involve amplified music? YES NO
 If yes, will the amplified music be a: Band DJ Other
 Hours of amplified music: 2 (on school grounds)
- I. Please list the number of security staff you will be providing for the event: 0
- J. Will you need barricades provided by the Village for your event? YES NO
 If yes, how many? 2 areas that need blocking hopefully by buses
- K. Will you be erecting any tents, canopies, or other temporary structure(s)? *If yes, please provide a plan for their proposed locations. The Fire Department and Building Inspection Department will need to inspect these structures prior to the start of your event.* YES NO
- L. Will you be providing portable restrooms and wash stations? *If yes, please provide a description of how many restrooms/wash stations will be provided, their locations, and the plan for how solid waste will be disposed of.* YES NO
- M. Will you provide parking for your participants? *If yes, please provide a plan describing where parking will be available.* YES NO
- N. Will you provide dumpster/clean-up services? *If yes, please provide a clean-up and refuse collection plan.* YES NO
- O. What other assistance do you foresee needing from the Village (personnel, materials, equipment, etc.)?
 We hope to have the Mukwonago Police Department presence. We would also love the fire department to bring a truck if available.
We would request a barricade at the intersections of Clarendon Avenue with E. Veterans Way & Lincoln Avenue.

- P. Have you reviewed and do you have a copy of the Village of Mukwonago Special Events Manual and the Village of Mukwonago Ordinance? YES NO

INSURANCE REQUIREMENTS

The Special Event Sponsor will provide evidence of liability insurance in a form acceptable to the Village Attorney, with limits of not less than \$1 Million per occurrence and \$2 Million in the aggregate, which coverage names the Village of Mukwonago, its officers, agents, employees and contractors as Additional Insured on a primary and non-contributory basis. Evidence of this coverage must be provided by a Policy Endorsement received by the Village not less than 20 days prior to the event. A Certificate of Insurance must evidence this coverage throughout the duration of the event. Applicant further agrees to indemnify and hold harmless the Village of Mukwonago, its officers, agents, employees, contractors and assigns, as and against any and all claims, demands, actions and causes of action, including actual attorney fees, arising from the Applicant's use of Village property and the issuance of this Permit.

Are you able to provide these insurance documents, if required?: YES NO

PROCEDURAL CHECKLIST FOR SPECIAL EVENT PERMIT REVIEW AND APPROVAL

This form is designed to be a guide for submitting a complete application for a special event.

Application:

- Completed application form including the procedural checklist.
- Application fee: see fee sheet.

Other Documents:

- Plan of operation/proposal.
- Overview of the site to be used for the event (layout of the event site).
- Any additional information as determined by Village staff.

DEPOSIT REQUIREMENTS

The applicant may be required to submit to the Village Clerk-Treasurer's Office a cleaning/damage deposit of \$200 for each scheduled day of the event (or portion thereof) two weeks prior to the starting date of the event. That deposit shall be refunded to the applicant, if, upon inspection, all is in order, or a prorated portion thereof as may be necessary to reimburse the Village for loss or cleaning costs. The Village reserves the right to retain the entire deposit if cleanup is not completed satisfactorily in the time frame as specified in the permit. Unless otherwise stated in the permit, the applicant shall be fully responsible for all necessary cleanup associated with the permitted event to be completed within 12 hours after the conclusion of the event. (This deposit is separate from any deposit required for rental of Village parks).

TERMINATION OF AN EVENT

The Village reserves the right to shut down a special event that is in progress if it is deemed to be a public safety hazard by the Police Department, Fire Department, and/or there is a violation of Village Ordinances, State Statutes or the terms of the applicant's permit. The Village Administrator and/or his/her designee may revoke an approved Special Events Permit if the applicant fails to comply in good faith with the provisions of the permit prior to the event date.

CERTIFICATION

By signing this form, the applicant certifies authorization to act on behalf of their organization, and hereby agrees to hold the Village, its officers, agents, employees, and contractors harmless against all claims, liability, loss, damage or expense (including but not limited to actual attorney fees) incurred by the Village for any damage or injury to person or property caused by or resulting directly or indirectly from the activities for which the permit is granted. Any change to coverage requires Village approval.

(The applicant's signature must be from a Managing Member if the business/organization is an LLC, or from the President or Vice President if the business/organization is a corporation. A signed applicant's authorization letter may be provided in lieu of the applicant's signature below.)

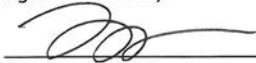

Signature - Applicant

Marnie Phillips- Art teacher

Name & Title (PRINT)

02/19/2025

Date

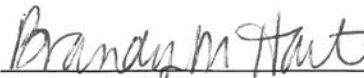

Signature - Applicant

Brandy Hart- Principal

Name & Title (PRINT)

02/19/2025

Date

FOR OFFICE USE ONLY			
Date Fees Paid	Receipt #	Date Deposit Paid	Deposit Returned?
Police Department:	Approved <input type="checkbox"/> Denied <input type="checkbox"/>	Comments:	_____
Fire Department:	Approved <input type="checkbox"/> Denied <input type="checkbox"/>	Comments:	_____
Public Works Department:	Approved <input type="checkbox"/> Denied <input type="checkbox"/>	Comments:	_____
Village Clerk:	Approved <input type="checkbox"/> Denied <input type="checkbox"/>	Comments:	_____
Village Board Approval Date	Village President Signature	Permit #	Issue Date

Special Events Permit Application (Rev 1.1.25)



POLICE & FIRE PLAN OF ACTION

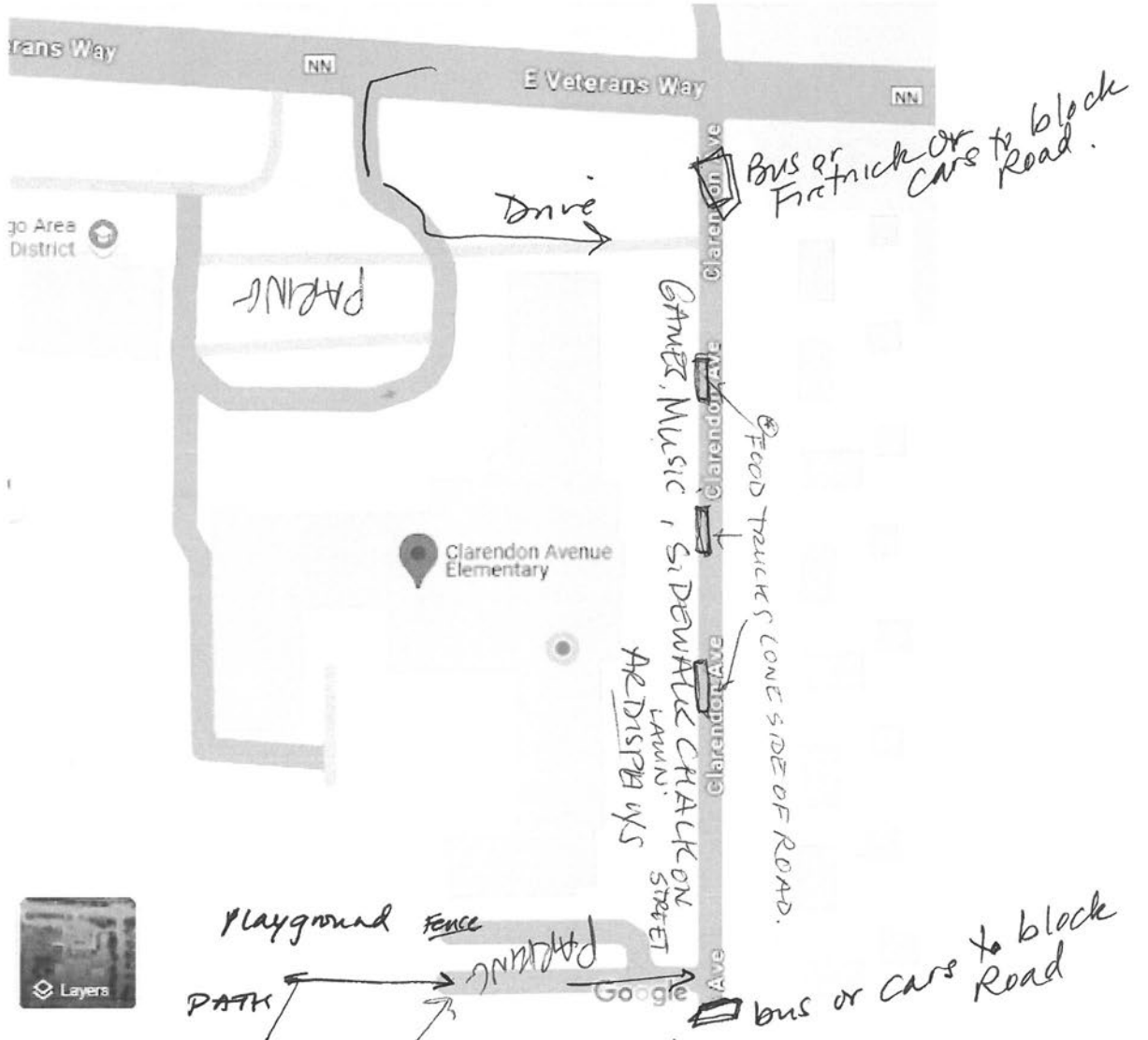

IF FOOD TRUCKS ARE A PROBLEM THE CAN BE PARKED IN THIS LOT.

- ① move buses to immediately access homes (if buses are available for blocking road.) (pedestrians move to ~~CLARENDON~~ ^{blocking} road.) Property)
- ② Access through driveways

Homeowners will park in Clarendon Lots, Lincoln Ave, ^{Harriet Ford.}

received a verbal yes from
912

OWNERNAME1	OWNERNAME2	PSTLADDRESS
CANDICE J BARBER		912 CLARENDON AVE, MUKWONAGO, WI 53149
AARON R LAUER	<i>Katherine Lauer</i>	930 CLARENDON AVE, MUKWONAGO, WI 53149
DONALD MUSZYNSKI	PORSCHA MUSZYNSKI	812 CLARENDON AVE, MUKWONAGO, WI 53149-1249
MARK A MACHAJEWSKI	DARLENE T MACHAJEWSKI	942 CLARENDON AVE, MUKWONAGO, WI 53149-1251
VALERIE J SCHULTZ		924 CLARENDON AVE, MUKWONAGO, WI 53149
ZACHARY P BUCHMANN	TERRY M BUCHMANN	918 CLARENDON AVE, MUKWONAGO, WI 53149
COLIN ECKLEY		936 CLARENDON AVE, MUKWONAGO, WI 53149-1251
BRIAN J WILL	CYNTHIA R WILL	900 CLARENDON AVE, MUKWONAGO, WI 53149-1251
SPENCER KRANZ		906 CLARENDON AVE, MUKWONAGO, WI 53149-1251

Katherine Lauer 930
Porsche Muszynski 812
Mark & Darlene
~~*Valerie Schultz*~~ 924
Zach Buchmann 918 2
Kai Eckley 936 2
~~*Brian Will*~~
~~*Spencer Kranz*~~ 906

Village of Mukwonago
 440 River Crest Court
 Mukwonago, WI 53149
 Phone: (262) 363-6420
 Fax: (262) 363-6425
www.villageofmukwonago.gov

VILLAGE OF MUKWONAGO

SPECIAL EVENT PERMIT APPLICATION

Application Fee: See fee sheet

Date Submitted: _____

Total Fees Paid: _____

Application must be received a minimum of 90 days prior to the special event. Fees are non-refundable. A minimum of \$10 fee for each special event. This fee is not included in the park or space rental.

Please refer to the Special Event Manual for step by step instructions.

Please select all the fees that apply for your event:

General Event Fees			
<input checked="" type="checkbox"/> Class I Event (Includes alcohol and/or amplified music)	\$20 per day		
<input type="checkbox"/> Class II Event	\$10 per day		
<input type="checkbox"/> Temporary Operator (Bartender) License	\$20 per event		
<i>*This License is only good for event</i>			
<input type="checkbox"/> Temporary Class B (Picnic) Beer and/or Wine License	\$10 per event		
<input type="checkbox"/> Park rental Permit	To Be Determined by event		
<input type="checkbox"/> Parade Permit (contact Police Dept)	\$25		
<input type="checkbox"/> Firework Permit (contact Fire Dept)	No Charge, State & Local Permits required		
<input type="checkbox"/> Security Deposit	\$200 per event (on top of park fees)		
Inspections			
<input type="checkbox"/> Pre-Event Safety Inspection	\$75 per hour		
<input type="checkbox"/> Electrical Inspection	\$75 per hour		
<input checked="" type="checkbox"/> Tent Inspection (<2,500 sq ft)	\$35		
<input type="checkbox"/> Tent Inspection (>2,500 sq ft)	\$50		
Total Fees: \$			
DEPARTMENT CONTACTS			
Clerk/Treasurer	(262) 363-6420 ext 2104	Police	(262) 363-6435
Building Inspection	(262) 363-6419	Public Works	(262) 363-6447
Fire	(262) 363-6426	Water/Sewer Utility	(262) 363-6416

ORGANIZATION INFORMATION

Name of Organization: Chris Hill

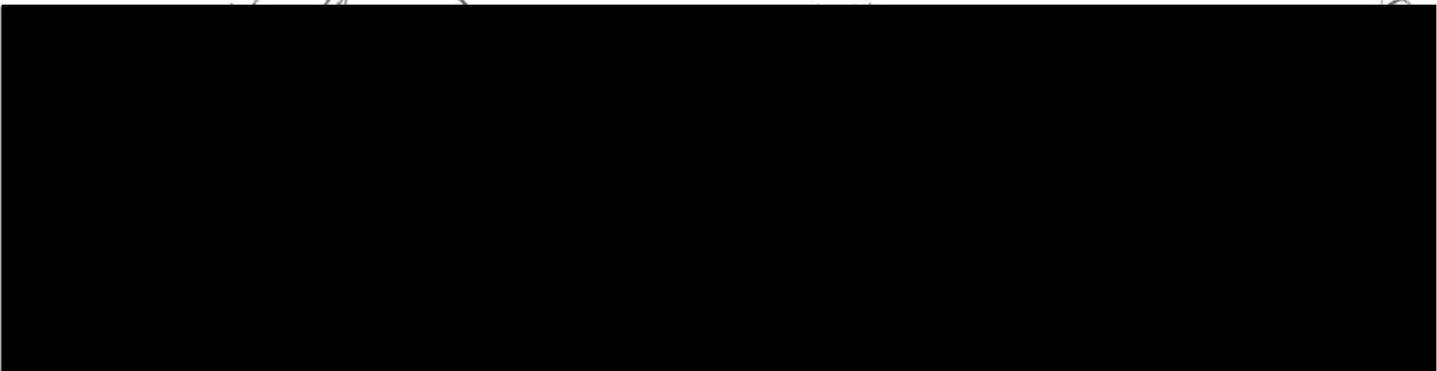

EVENT INFORMATION

Name of the Event: 70+80's Reunion Date(s) of the Event: 8-30-2025

Event Start Time: 1:00 pm Event End Time: 9:00 pm

Location of the Event: Mukwonago Field Park

A. Will your event take place in a residential neighborhood? *If yes, you will be required to notify all adjacent property owners when the event will occur.* YES NO

B. Please provide your COVID-19 Action Plan.

C. You MUST attach a detailed map/sketch of your event indicating the specific location, layout of your event, and the direction of the route, including all turns and the number of traffic lanes to be used.

D. If you are using a Village park, you must reserve the park through the Village Clerk-Treasurer's Office prior to getting your special event permit approved by the Village Board. Call 262-363-6420 ext 2104.

E. Briefly describe your event and its purpose.
A multiple year class reunion

F. Based on the class definitions found in the manual, what class is your event? CLASS I CLASS II

G. Estimated # of participants: 150 Spectators: _____ Vendors: _____

OTHER INFORMATION

A. Is there an outdoor bar that will serve alcohol? *If yes, temporary Class B beer and/or wine (picnic) and operator (bartender) licenses are necessary under separate application.* YES NO

B. Please list the number of Village of Mukwonago licensed bartenders that will be on site: _____

C. Will you be selling/serving food? *If yes, you will need to contact Waukesha County Health Department (262-896-8300) for proper permits.* YES NO

D. Will your event need electricity? *If yes, the Fire Department and Building Inspection Department will need to inspect prior to being energized.* YES NO

E. Will you be setting up any lighting? *If yes, the Fire Department and Building Inspection Department will need to inspect prior to being energized.* YES NO

F. Will your event require any fencing? *If yes, please provide plans for the fencing location and the gates.* YES NO

G. Does your event involve fireworks? *If yes, you will need to contact the Fire Department (262-363-6426) for proper permits.* YES NO

H. Does your event involve amplified music? YES NO

If yes, will the amplified music be a: Band DJ Other

Hours of amplified music: 4-9 pm

I. Please list the number of security staff you will be providing for the event: 0

J. Will you need barricades provided by the Village for your event? YES NO

If yes, how many? 4

K. Will you be erecting any tents, canopies, or other temporary structure(s)? *If yes, please provide a plan for their proposed locations. The Fire Department and Building Inspection Department will need to inspect these structures prior to the start of your event.* YES NO

L. Will you be providing portable restrooms and wash stations? *If yes, please provide a description of how many restrooms/wash stations will be provided, their locations, and the plan for how solid waste will be disposed of.* YES NO

M. Will you provide parking for your participants? **If yes, please provide a plan describing where parking will be available.** YES NO

N. Will you provide dumpster/clean-up services? **If yes, please provide a clean-up and refuse collection plan.** YES NO

O. What other assistance do you foresee needing from the Village (personnel, materials, equipment, etc.)?

Does the village have a dumpster to get rid of trash?
If not, I will remove the trash from the park.

P. Have you reviewed and do you have a copy of the **Village of Mukwonago Special Events Manual** and the **Village of Mukwonago Ordinance**? YES NO

INSURANCE REQUIREMENTS

The Special Event Sponsor will provide evidence of liability insurance in a form acceptable to the Village Attorney, with limits of not less than \$1 Million per occurrence and \$2 Million in the aggregate, which coverage names the Village of Mukwonago, its officers, agents, employees and contractors as Additional Insured on a primary and non-contributory basis. Evidence of this coverage must be provided by a Policy Endorsement received by the Village not less than 20 days prior to the event. A Certificate of Insurance must evidence this coverage throughout the duration of the event. Applicant further agrees to indemnify and hold harmless the Village of Mukwonago, its officers, agents, employees, contractors and assigns, as and against any and all claims, demands, actions and causes of action, including actual attorney fees, arising from the Applicant's use of Village property and the issuance of this Permit.

Are you able to provide these insurance documents, if required?: YES NO

PROCEDURAL CHECKLIST FOR SPECIAL EVENT PERMIT REVIEW AND APPROVAL

This form is designed to be a guide for submitting a complete application for a special event.

Application:

- Completed application form including the procedural checklist.
- Application fee: see fee sheet.

Other Documents:

- Plan of operation/proposal.
- Overview of the site to be used for the event (layout of the event site).
- Any additional information as determined by Village staff.

DEPOSIT REQUIREMENTS

The applicant may be required to submit to the Village Clerk-Treasurer's Office a cleaning/damage deposit of \$200 for each scheduled day of the event (or portion thereof) two weeks prior to the starting date of the event. That deposit shall be refunded to the applicant, if, upon inspection, all is in order, or a prorated portion thereof as may be necessary to reimburse the Village for loss or cleaning costs. The Village reserves the right to retain the entire deposit if cleanup is not completed satisfactorily in the time frame as specified in the permit. Unless otherwise stated in the permit, the applicant shall be fully responsible for all necessary cleanup associated with the permitted event to be completed within 12 hours after the conclusion of the event. (This deposit is separate from any deposit required for rental of Village parks).

TERMINATION OF AN EVENT

The Village reserves the right to shut down a special event that is in progress if it is deemed to be a public safety hazard by the Police Department, Fire Department, and/or there is a violation of Village Ordinances, State Statutes or the terms of the applicant's permit. The Village Administrator and/or his/her designee may revoke an approved Special Events Permit if the applicant fails to comply in good faith with the provisions of the permit prior to the event date.

CERTIFICATION

By signing this form, the applicant certifies authorization to act on behalf of their organization, and hereby agrees to hold the Village, its officers, agents, employees, and contractors harmless against all claims, liability, loss, damage or expense (including but not limited to actual attorney fees) incurred by the Village for any damage or injury to person or property caused by or resulting directly or indirectly from the activities for which the permit is granted. Any change to coverage requires Village approval.

(The applicant's signature must be from a Managing Member if the business/organization is an LLC, or from the President or Vice President if the business/organization is a corporation. A signed applicant's authorization letter may be provided in lieu of the applicant's signature below.)

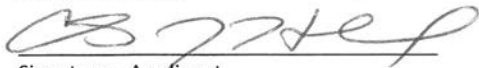

Signature - Applicant

Chris J. Hill

Name & Title (PRINT)

2-5-2025

Date

Signature - Applicant

Name & Title (PRINT)

Date

FOR OFFICE USE ONLY

Date Fees Paid	Receipt #	Date Deposit Paid	Deposit Returned?
Police Department: Approved <input type="checkbox"/> Denied <input type="checkbox"/> Comments: _____ Fire Department: Approved <input type="checkbox"/> Denied <input type="checkbox"/> Comments: _____ Public Works Department: Approved <input type="checkbox"/> Denied <input type="checkbox"/> Comments: _____ Village Clerk: Approved <input type="checkbox"/> Denied <input type="checkbox"/> Comments: _____			
Village Board Approval Date	Village President Signature	Permit #	Issue Date



Agenda Cover Report

Date: 3/26/25	Committee/Board: Health and Recreation
Submitted by: Ron Bittner	Department: Public Works
Date of Committee Action: 4/2/25	Date of Village Board Action: 4/16/25

Subject: Phantom Glen Park ADA fishing pier deck replacement.
Executive Summary: The decking on the pier is at its end of life. The wood is cracking and deteriorating beyond repair. The project was included in the 2025 CIP as part of the park system's long term maintenance strategy.

Attachments Included

ESTIMATE



Prepared For

Village Of Mukwonago
440 River Crest Court
Mukwonago, Wi 53149
(262) 363-6420

Home Run Remodeling LLC

238 SOUTH GREENFIELD AVE
Waukesha, Wi 53186
Phone: (262) 888-3470
Email: admin@homerunremodelingllc.com

Estimate # 66
Date 02/27/2025
PO # fishing pier
Business / Tax # 93-3443572

Description

Haul-Away and Disposal

Dumpster(s)

Materials- Hardware

Hardware materials

Materials - treated lumber

Pressure treated :

-8'x49' walkway

-8'x6' ramp

-16'x41' fishing platform

- railings around perimeter of above listed

2x6 Deck Boards

2x6 Handrail

2x4 Handrail supports

2x12 fishing platform ledges

4x4 railing posts

Galvanized bolts to secure 4x4 railing post

Lifetime guarantee coated deck screws

Demo

Removal of all existing deck boards, and hand rail

Installation

Install new deck boards, posts and hand rails, fishing platforms

Subtotal	\$34,129.39
-----------------	-------------

Total	\$34,129.39
--------------	--------------------

By signing this document, the customer agrees to the services and conditions outlined in this document.

Ben Schubring

Village Of Mukwonago

Casper's Improvements

W344S10443 County Road E
Mukwonago, WI 53149

Phone # 262-470-9869 CASPERSIMPROVEMENTS@GMAIL....

Estimate

Date	Estimate #
2/3/2025	1288

Name / Address
Village of Mukwonago Ron Bittner

			Project
Description	Qty	Rate	Total
Secure area with 4x4's lock and chain. Remove and dispose of all existing boards.(remove handrail save for reinstall.) Rebuild to match: existing pier, railings, including fishing pole holders. (benches not included) Green treated ground contact lumber. exterior decking screws. While I will take all necessary precautions, I cannot be held responsible for any additional costs due to vandalism or theft of materials. This estimate includes materials. The price is contingent upon current market prices. Any increase in material costs at the time of purchase will be reflected in the final invoice. This estimate covers the scope of work as outlined. Any additional unexpected work that arises during the project, will be considered extra and will incur additional charges. (i.e., any additional work to floats, struts, etc.) Payment - 20% down, 30% due after demo and remaining 50% due upon completion. MISC MATERIALS AND REPAIR		72,000.00	72,000.00
CASPER'S IMPROVEMENTS		Total	\$72,000.00

Attn. Mr. Ron Bittner

Please contact me on a time when we can meet to discuss any questions you may have.

**Sincerely,
Campbell Construction
"The Future is Building"**

Jay Campbell
Jay Campbell

Wayne Johnson
Wayne Johnson

Village of Mukwonago
 440 River Crest Court
 Mukwonago, WI 53149
 Phone: (262) 363-6420
 Fax: (262) 363-6425
www.villageofmukwonago.gov

VILLAGE OF MUKWONAGO SPECIAL EVENT PERMIT APPLICATION

Application Fee: See fee sheet

Date Submitted: _____

Total Fees Paid: _____

Application must be received a minimum of 90 days prior to the special event. Fees are non-refundable. A minimum of \$10 fee for each special event. This fee is not included in the park or space rental.

Please refer to the Special Event Manual for step by step instructions.

Please select all the fees that apply for your event:

General Event Fees

- | | |
|--|---|
| <input type="checkbox"/> Class I Event (Includes alcohol and/or amplified music) | \$20 per day |
| <input type="checkbox"/> Class II Event | \$10 per day |
| <input type="checkbox"/> Temporary Operator (Bartender) License | \$20 per event |
| *This License is only good for event | |
| <input type="checkbox"/> Temporary Class B (Picnic) Beer and/or Wine License | \$10 per event |
| <input type="checkbox"/> Park rental Permit | To Be Determined by event |
| <input type="checkbox"/> Parade Permit (contact Police Dept) | \$25 |
| <input type="checkbox"/> Firework Permit (contact Fire Dept) | No Charge, State & Local Permits required |
| <input type="checkbox"/> Security Deposit | \$200 per event (on top of park fees) |

Inspections

- | | |
|---|---------------|
| <input type="checkbox"/> Pre-Event Safety Inspection | \$75 per hour |
| <input type="checkbox"/> Electrical Inspection | \$75 per hour |
| <input type="checkbox"/> Tent Inspection (<2,500 sq ft) | \$35 |
| <input type="checkbox"/> Tent Inspection (>2,500 sq ft) | \$50 |

Total Fees: \$

DEPARTMENT CONTACTS

Clerk/Treasurer	(262) 363-6420 ext 2104	Police	(262) 363-6435
Building Inspection	(262) 363-6419	Public Works	(262) 363-6447
Fire	(262) 363-6426	Water/Sewer Utility	(262) 363-6416

ORGANIZATION INFORMATION

Name of Organization: Mukwonago Community American Legion Post 323
 Mailing Address: 627 E Veterans way City: Mukwonago State: WI Zip: 53145

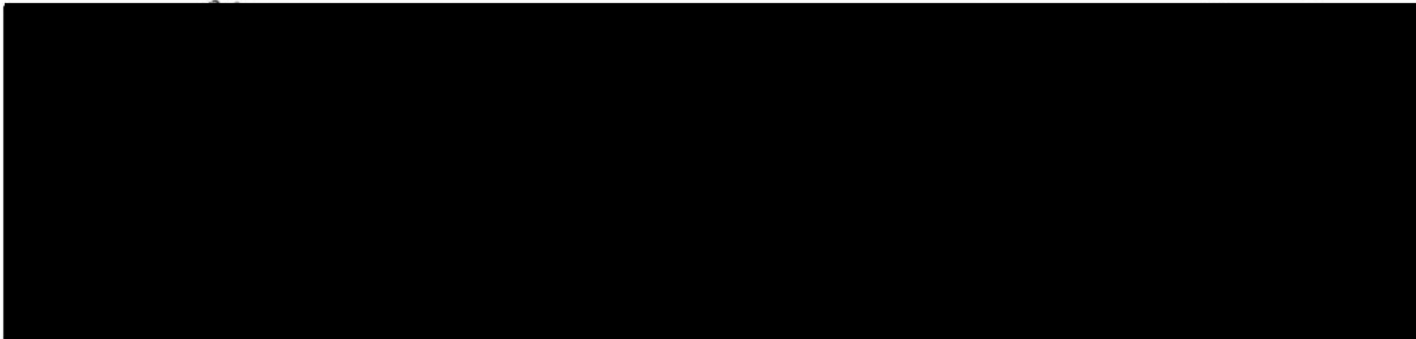

EVENT INFORMATION

Name of the Event: Memorial Day Parade Date(s) of the Event: MAY 26th 2025

Event Start Time: 9 AM Event End Time: 12 PM

Location of the Event: West Parkview Middle School / East Mukwonago Library

A. Will your event take place in a residential neighborhood? *If yes, you will be required to notify all adjacent property owners when the event will occur.* YES NO

B. Please provide your COVID-19 Action Plan.

C. You MUST attach a detailed map/sketch of your event indicating the specific location, layout of your event, and the direction of the route, including all turns and the number of traffic lanes to be used.

D. If you are using a Village park, you must reserve the park through the Village Clerk-Treasurer's Office prior to getting your special event permit approved by the Village Board. Call 262-363-6420 ext 2104.

E. Briefly describe your event and its purpose.

Annual Parade To honor all Veterans on Memorial Day

F. Based on the class definitions found in the manual, what class is your event? CLASS I CLASS II

G. Estimated # of participants: 150 Spectators: many Vendors: NO

OTHER INFORMATION

A. Is there an outdoor bar that will serve alcohol? *If yes, temporary Class B beer and/or wine (picnic) and operator (bartender) licenses are necessary under separate application.* YES NO

B. Please list the number of Village of Mukwonago licensed bartenders that will be on site: 0

C. Will you be selling/serving food? *If yes, you will need to contact Waukesha County Health Department (262-896-8300) for proper permits.* YES NO

D. Will your event need electricity? *If yes, the Fire Department and Building Inspection Department will need to inspect prior to being energized.* YES NO

E. Will you be setting up any lighting? *If yes, the Fire Department and Building Inspection Department will need to inspect prior to being energized.* YES NO

F. Will your event require any fencing? *If yes, please provide plans for the fencing location and the gates.* YES NO

G. Does your event involve fireworks? *If yes, you will need to contact the Fire Department (262-363-6426) for proper permits.* YES NO

H. Does your event involve amplified music? YES NO

If yes, will the amplified music be a: Band DJ Other

Hours of amplified music: _____

I. Please list the number of security staff you will be providing for the event: 0

J. Will you need barricades provided by the Village for your event? YES NO

If yes, how many? Same as Previous Years

K. Will you be erecting any tents, canopies, or other temporary structure(s)? *If yes, please provide a plan for their proposed locations. The Fire Department and Building Inspection Department will need to inspect these structures prior to the start of your event.* YES NO

L. Will you be providing portable restrooms and wash stations? *If yes, please provide a description of how many restrooms/wash stations will be provided, their locations, and the plan for how solid waste will be disposed of.* YES NO

- M. Will you provide parking for your participants? If yes, please provide a plan describing where parking will be available. YES NO
- N. Will you provide dumpster/clean-up services? If yes, please provide a clean-up and refuse collection plan. YES NO
- O. What other assistance do you foresee needing from the Village (personnel, materials, equipment, etc.)?
 Police Control of Traffic

- P. Have you reviewed and do you have a copy of the Village of Mukwonago Special Events Manual and the Village of Mukwonago Ordinance? YES NO

INSURANCE REQUIREMENTS

The Special Event Sponsor will provide evidence of liability insurance in a form acceptable to the Village Attorney, with limits of not less than \$1 Million per occurrence and \$2 Million in the aggregate, which coverage names the Village of Mukwonago, its officers, agents, employees and contractors as Additional Insured on a primary and non-contributory basis. Evidence of this coverage must be provided by a Policy Endorsement received by the Village not less than 20 days prior to the event. A Certificate of Insurance must evidence this coverage throughout the duration of the event. Applicant further agrees to indemnify and hold harmless the Village of Mukwonago, its officers, agents, employees, contractors and assigns, as and against any and all claims, demands, actions and causes of action, including actual attorney fees, arising from the Applicant's use of Village property and the issuance of this Permit.

Are you able to provide these insurance documents, if required?: YES NO

PROCEDURAL CHECKLIST FOR SPECIAL EVENT PERMIT REVIEW AND APPROVAL

This form is designed to be a guide for submitting a complete application for a special event.

Application:

- Completed application form including the procedural checklist.
- Application fee: see fee sheet.

Other Documents:

- Plan of operation/proposal.
- Overview of the site to be used for the event (layout of the event site).
- Any additional information as determined by Village staff.

DEPOSIT REQUIREMENTS

The applicant may be required to submit to the Village Clerk-Treasurer's Office a cleaning/damage deposit of \$200 for each scheduled day of the event (or portion thereof) two weeks prior to the starting date of the event. That deposit shall be refunded to the applicant, if, upon inspection, all is in order, or a prorated portion thereof as may be necessary to reimburse the Village for loss or cleaning costs. The Village reserves the right to retain the entire deposit if cleanup is not completed satisfactorily in the time frame as specified in the permit. Unless otherwise stated in the permit, the applicant shall be fully responsible for all necessary cleanup associated with the permitted event to be completed within 12 hours after the conclusion of the event. (This deposit is separate from any deposit required for rental of Village parks).

TERMINATION OF AN EVENT

The Village reserves the right to shut down a special event that is in progress if it is deemed to be a public safety hazard by the Police Department, Fire Department, and/or there is a violation of Village Ordinances, State Statutes or the terms of the applicant's permit. The Village Administrator and/or his/her designee may revoke an approved Special Events Permit if the applicant fails to comply in good faith with the provisions of the permit prior to the event date.

CERTIFICATION

By signing this form, the applicant certifies authorization to act on behalf of their organization, and hereby agrees to hold the Village, its officers, agents, employees, and contractors harmless against all claims, liability, loss, damage or expense (including but not limited to actual attorney fees) incurred by the Village for any damage or injury to person or property caused by or resulting directly or indirectly from the activities for which the permit is granted. Any change to coverage requires Village approval.

(The applicant's signature must be from a Managing Member if the business/organization is an LLC, or from the President or Vice President if the business/organization is a corporation. A signed applicant's authorization letter may be provided in lieu of the applicant's signature below.)

Pat Hays
Signature - Applicant

Signature - Applicant

Patrick Hays Comm.tee Chair
Name & Title (PRINT)

Name & Title (PRINT)

3-25-25
Date

Date

FOR OFFICE USE ONLY			
Date Fees Paid	Receipt #	Date Deposit Paid	Deposit Returned?
Police Department:	Approved <input type="checkbox"/> Denied <input type="checkbox"/>	Comments: _____	
Fire Department:	Approved <input type="checkbox"/> Denied <input type="checkbox"/>	Comments: _____	
Public Works Department:	Approved <input type="checkbox"/> Denied <input type="checkbox"/>	Comments: _____	
Village Clerk:	Approved <input type="checkbox"/> Denied <input type="checkbox"/>	Comments: _____	
Village Board Approval Date	Village President Signature	Permit #	Issue Date

Village of Mukwonago
440 River Crest Court
Mukwonago, WI 53149
Phone: (262) 363-6420
Fax: (262) 363-6425
www.villageofmukwonago.gov

VILLAGE OF MUKWONAGO SPECIAL EVENT PERMIT APPLICATION

Application Fee: See fee sheet

PAID
CA NO
DATE

Date Submitted: _____

Total Fees Paid: 20 - X

Application must be received a minimum of 90 days prior to the special event. Fees are non-refundable.

ORGANIZATION INFORMATION

Name of Organization: American Legion Post #375
Mailing Address: PO Box 152 City: Mukwonago State: WI Zip: 53149
Phone Number: 262-363-3580 Is the organization a 501(c)3 organization?: YES NO
Website Address: www.Post375.org



Name of the Event: Maxwell Street Days Date(s) of the Event: 6/7-8 7/19-20 8/16-17 9/13-14
Event Start Time: 0600 Event End Time: 1700
Location of the Event: Field Park

- A. Will your event take place in a residential neighborhood? *If yes, you will be required to notify all adjacent property owners when the event will occur.* YES NO
- B. Please provide your COVID-19 Action Plan. COVID PLAN REMAINS UNCHANGED FROM PREVIOUS YEARS.
- C. You MUST attach a detailed map/sketch of your event indicating the specific location, layout of your event, and the direction of the route, including all turns and the number of traffic lanes to be used.
- D. If you are using a Village park, you must reserve the park through the Village Clerk-Treasurer's Office prior to getting your special event permit approved by the Village Board. Call 262-363-6420 ext 2104.
- E. Briefly describe your event and its purpose.

Flea Market Vendors on Grounds Selling A Variety of Goods and Services

F. Based on the class definitions found in the manual, what class is your event? CLASS I CLASS II

G. Estimated # of participants: 6000 Spectators: 5500 Vendors: 500

PROCEDURAL CHECKLIST FOR SPECIAL EVENT PERMIT REVIEW AND APPROVAL

This form is designed to be a guide for submitting a complete application for a special event.

Application:

- Completed application form including the procedural checklist.
- Application fee: see fee sheet.

Other Documents:

- Plan of operation/proposal.
- Overview of the site to be used for the event (layout of the event site).
- Any additional information as determined by Village staff.

DEPOSIT REQUIREMENTS

The applicant may be required to submit to the Village Clerk-Treasurer's Office a cleaning/damage deposit of \$200 for each scheduled day of the event (or portion thereof) two weeks prior to the starting date of the event. That deposit shall be refunded to the applicant, if, upon inspection, all is in order, or a prorated portion thereof as may be necessary to reimburse the Village for loss or cleaning costs. The Village reserves the right to retain the entire deposit if cleanup is not completed satisfactorily in the time frame as specified in the permit. Unless otherwise stated in the permit, the applicant shall be fully responsible for all necessary cleanup associated with the permitted event to be completed within 12 hours after the conclusion of the event. (This deposit is separate from any deposit required for rental of Village parks).

TERMINATION OF AN EVENT

The Village reserves the right to shut down a special event that is in progress if it is deemed to be a public safety hazard by the Police Department, Fire Department, and/or there is a violation of Village Ordinances, State Statutes or the terms of the applicant's permit. The Village Administrator and/or his/her designee may revoke an approved Special Events Permit if the applicant fails to comply in good faith with the provisions of the permit prior to the event date.

CERTIFICATION

By signing this form, the applicant certifies authorization to act on behalf of their organization, and hereby agrees to hold the Village, its officers, agents, employees, and contractors harmless against all claims, liability, loss, damage or expense (including but not limited to actual attorney fees) incurred by the Village for any damage or injury to person or property caused by or resulting directly or indirectly from the activities for which the permit is granted. Any change to coverage requires Village approval.

(The applicant's signature must be from a Managing Member if the business/organization is an LLC, or from the President or Vice President if the business/organization is a corporation. A signed applicant's authorization letter may be provided in lieu of the applicant's signature below.)

Signature - Applicant

Timothy J. Flory / Vice Commander
Name & Title (PRINT)

2-18-25
Date

Signature - Applicant

GEORGE MIELKE 1ST VICE
Name & Title (PRINT)

02-18-25
Date

FOR OFFICE USE ONLY			
Date Fees Paid	Receipt #	Date Deposit Paid	Deposit Returned?
Police Department: Approved <input type="checkbox"/> Denied <input type="checkbox"/> Comments: _____ Fire Department: Approved <input type="checkbox"/> Denied <input type="checkbox"/> Comments: _____ Public Works Department: Approved <input type="checkbox"/> Denied <input type="checkbox"/> Comments: _____ Village Clerk: Approved <input type="checkbox"/> Denied <input type="checkbox"/> Comments: _____			
Village Board Approval Date	Village President Signature	Permit #	Issue Date

ORDINANCE NO. _____

An Ordinance to Allow Electronic “Reader Board” Signs to Refresh at a Rate of Once Every Fifteen Seconds

WHEREAS, currently Chapter 64 of the Village of Mukwonago Municipal Code (“Code”) mandates that electronic “reader boards” as defined in the Code only be allowed to refresh at a rate of once per minute for general messages, and once every 10 seconds for time and temperature displays; and

WHEREAS, upon discussion and study of suggested guidelines for electronic “reader board” signs displaying in areas other than along an interstate highway, it was determined that more frequent change intervals would still serve public health and safety; and

WHEREAS, local businesses also desire to have a lower threshold for display length on electronic “reader board” signs; and

WHEREAS, the Board also finds it best to harmonize display times with one standard, rather than have a separate length for time and temperature displays; and

WHEREAS, message display length on electronic “reader boards” along the interstate highway will still be governed by Wis. Stat. § 84.30, as preempted by state law;

NOW THEREFORE, at a regular meeting of the Village Board of the Village of Mukwonago, Waukesha County, Wisconsin, held on the 16th day of April, 2025, by a favorable vote of the Board, said Board does ordain as follows:

SECTION 1

The definition of “Reader Board,” as found in Section 8, “Definitions,” of Article I, “In General,” of Chapter 64, “Sign Code,” of the Municipal Code of the Village of Mukwonago, is hereby repealed and replaced as follows:

READER BOARD

A portion of a sign on which letters and other sign copy are readily replaceable either manually or electronically such that copy can be changed from time to time at will, and with copy changed at a frequency of at least once every six months; however individual applied letters shall be changed at a frequency of at least once every seven days. Electronic messages shall be allowed to change no more frequently than once every 15 seconds, except for Reader Board signs along an interstate highway, where the display criteria is preempted by Wis. Stat. § 84.30. A reader board includes other terms such as changeable copy sign, message board, electronic message center or LED message board. A reader board is not a menu board.

SECTION 2

Subsection (j)(4)a. of Section 22, “Village center business and manufacturing zoning permanent sign standards requiring a permit,” of Article II, “Regulations and Standards,” of Chapter 64, “Sign Code,” is hereby repealed and replaced as follows:

§ 64-22(j):

(4) Reader board copy. Reader board copy shall adhere to the following standards:

a. Cyclical copy on an illuminated reader board sign shall be allowed to change no more frequently than once every 15 seconds, except for Reader Board signs along an interstate highway, where the display criteria is preempted by Wis. Stat. § 84.30.

SECTION 3

Subsection (j)(4)a. of Section 23, “Village proper business and manufacturing zoning permanent sign standards requiring a permit,” of Article II, “Regulations and Standards,” of Chapter 64, “Sign Code,” is hereby repealed and replaced as follows:

§ 64-23(j):

(4) Reader board copy. Reader board copy shall adhere to the following standards:

a. Cyclical copy on an illuminated reader board sign shall be allowed to change no more frequently than once every 15 seconds, except for Reader Board signs along an interstate highway, where the display criteria is preempted by Wis. Stat. § 84.30.

SECTION 4

That all Ordinances or parts of Ordinances conflicting with the provisions of this Ordinance are hereby to such extent repealed.

SECTION 5

If any portion of this Ordinance is invalid or unconstitutional, or the application of this Ordinance to any person or circumstances is invalid or unconstitutional, such invalidity or unconstitutionality shall not affect the other provisions or applications of this Ordinance which can be given effect without the invalid or unconstitutional provisions or applications.

SECTION 6

That this Ordinance shall take effect and be in force from and after its passage and posting as provided by law, and the Village Clerk shall so amend the Code of Ordinances of the Village of Mukwonago and shall indicate the number of this amending ordinance therein.

PASSED AND ADOPTED by the Village Board of the Village of Mukwonago, Waukesha County, Wisconsin, this 16th day of April, 2025.

Fred Winchowky, Village President, Board of Trustees

Countersigned:

Lana Kropf, Village Clerk-Treasurer

Form
AB-200

Alcohol Beverage License Application

For Municipal Use Only	
Municipality	V. Mukwonago
License Period	APR 2025 - 10/30/2026

License(s) Requested: (up to two boxes may be checked)

- Class "A" Beer \$ _____
 Class "B" Beer \$ 100.00
- "Class A" Liquor \$ _____
 "Class B" Liquor \$ _____
- "Class A" Liquor (cider only) \$ _____
 Reserve "Class B" Liquor \$ _____
- "Class C" Liquor (wine only) \$ _____

Fees	
License Fees	\$ 100 ⁻
Background Check Fee	\$ 10 ⁻
Publication Fee	\$ 25 ⁻
Total Fees	\$ 135⁻

PAID

MAR 04 2025

Part A: Premises/Business Information

1. Legal Business Name (individual name if sole proprietorship) <u>NAJERA BROTHERS COMPANY LLC</u>			
2. Business Trade Name or DBA <u>GENOAS PIZZA</u>			
3. FEIN <u>92-1186558</u>		4. Wisconsin Seller's Permit Number <u>456-1031193761-04</u>	
5. Entity Type (check one) <input type="checkbox"/> Sole Proprietor <input type="checkbox"/> Partnership <input checked="" type="checkbox"/> Limited Liability Company <input type="checkbox"/> Corporation <input type="checkbox"/> Nonprofit Organization			
6. State of Organization <u>WI</u>		7. Date of Organization <u>11/30/2022</u>	8. Wisconsin DFI Registration Number <u>N058445</u>
9. Premises Address <u>225 BAYVIEW RD STE 500</u>			
10. City <u>MUKWONAGO</u>		11. State <u>WI</u>	12. Zip Code <u>53149</u>
13. County <u>WAUKESHA</u>		14. Governing Municipality: <input type="checkbox"/> City <input type="checkbox"/> Town <input checked="" type="checkbox"/> Village of: <u>Mukwonago</u>	15. Aldermanic District
16. Premises Phone <u>262-368-5336</u>		17. Premises Email	18. Website
19. Premises Description - Describe the building or buildings where alcohol beverages are produced, sold, stored, or consumed, and related records are kept. Describe all rooms within the building, including living quarters. Authorized alcohol beverage activities and storage of records may occur only on the premises described in this application. Attach a map or diagram and additional sheets if necessary. <u>Certified Servers will serve alcohol beverages in the buildings dining room. Alcohol will be stored in the back of the building in the walk-in cooler.</u>			



1. Has the business (sole proprietorship, partnership, limited liability company, or corporation) been convicted of violating federal or state laws or local ordinances? Exclude traffic offenses unless related to alcohol beverages. Yes No

If yes, list the details of violation below. Attach additional sheets if necessary.

Law/Ordinance Violated	Location	Trial Date
Penalty Imposed	Was sentence completed? <input type="checkbox"/> Yes <input type="checkbox"/> No	
Law/Ordinance Violated	Location	Trial Date
Penalty Imposed	Was sentence completed? <input type="checkbox"/> Yes <input type="checkbox"/> No	

2. Are charges for any offenses pending against the business? Exclude traffic offenses unless related to alcohol . . . Yes No beverages.
 If yes, describe the nature and status of pending charges using the space below. Attach additional sheets as needed.

3. Is the applicant business or any of its officers, directors, members, agent, employees, owners, or other related individuals or entities a restricted investor with any interest in an alcohol beverage producer or distributor? . . . Yes No
 If yes, provide the name of the restricted investor and describe the nature of the interest.

4. Is the applicant business owned by another business entity? . . . Yes No
 If yes, provide the name(s) and FEIN(s) of the business entity owners below. Attach additional sheets as needed.

4a. Name of Business Entity	4b. Business Entity FEIN
-----------------------------	--------------------------

5. Have the partners, agent, or sole proprietor satisfied the responsible beverage server training requirement for this license period? Submit proof of completion. Yes No
 6. Is the applicant business indebted to any wholesaler beyond 15 days for beer or 30 days for liquor/wine? Yes No
 7. Does the applicant business owe past due municipal property taxes, assessments, or other fees? Yes No

Part C: Individual Information

List the name, title, and phone number for each person or entity holding the following positions in the applicant business or businesses listed in Part B, Question 4: sole proprietor, all officers, directors, and agent of a corporation or nonprofit organization, all partners of a partnership, and all members, managers, and agent of a limited liability company. Attach additional sheets if necessary.

Include Form AB-100 for each person listed below. Corporations and LLCs must appoint an agent by including Form A

Last Name	First Name	Title
NAJERA	BULFRANO	CO-owner
NAJERA	EFREN	CO-owner

Part D: Attestation

One of the following must sign and attest to this application:

- sole proprietor
- one general partner of a partnership
- one corporate officer
- one member of an LLC

READ CAREFULLY BEFORE SIGNING: Under penalty of law, I have answered each of the above questions completely and truthfully. I agree that I am acting solely on behalf of the applicant business and not on behalf of any other individual or entity seeking the license. Further, I agree that the rights and responsibilities conferred by the license(s), if granted, will not be assigned to another individual or entity. I agree to operate this business according to the law, including but not limited to, purchasing alcohol beverages from state authorized wholesalers. I understand that lack of access to any portion of a licensed premises during inspection will be deemed a refusal to allow inspection. Such refusal is a misdemeanor and grounds for revocation of this license. I understand that any license issued contrary to Wis. Stat. Chapter 125 shall be void under penalty of state law. I further understand that I may be prosecuted for submitting false statements and affidavits in connection with this application, and that any person who knowingly provides materially false information on this application may be required to forfeit not more than \$1,000 if convicted.

Last Name	First Name	M.I.
NAJERA	BULFRANO	C
Title	Email	Phone

Signature	Date
	03/04/2025

Part E: For Clerk Use Only

Date Application Was Filed With Clerk	License Number	Date License Granted	Date License Issued
3/4/2025			
Signature of Clerk/Deputy Clerk		Date Provisional License Issued (if applicable)	

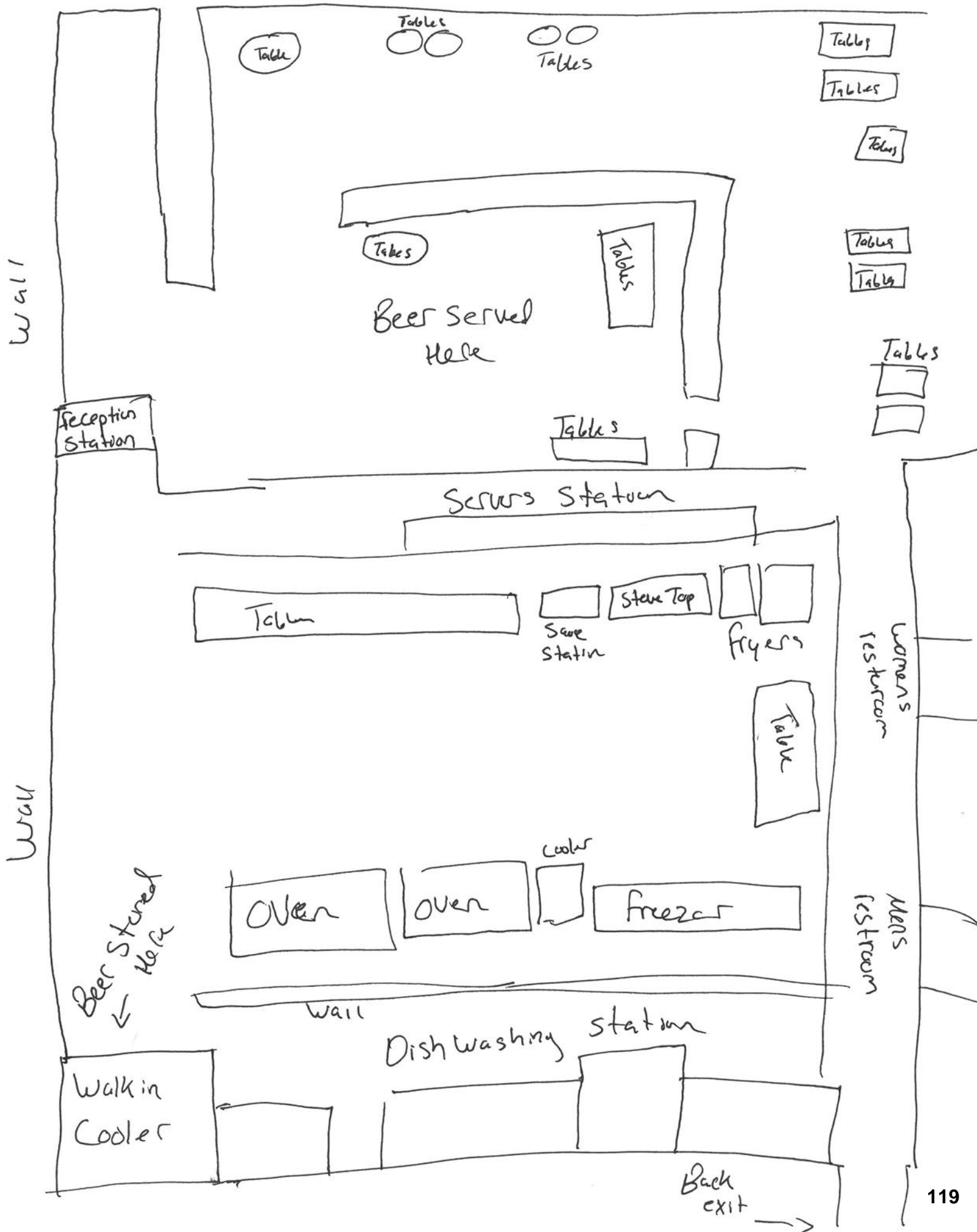



State of Wisconsin • DEPARTMENT OF REVENUE

Personal Wallet Copy

Seller's Permit: 456-1031193761-04

Legal/Real Name: NAJERAS BROTHERS COMPANY LLC

Signature _____

Form
AB-101

Alcohol Beverage Appointment of Agent

Date

Agent Type (check one)

- Original (no fee) Successor (\$10 fee for municipal licensees only)

Part A: Business Information

1. Legal Business Name (individual name if sole proprietor) NAJERA BROTHERS COMPANY LLC	
2. Business Trade Name or DBA GENOAS PIZZA	
3. Entity Type (check one) <input checked="" type="checkbox"/> Limited Liability Company <input type="checkbox"/> Corporation <input type="checkbox"/> Nonprofit Organization	
4. Alcohol Beverage Business Authorization (check one) <input checked="" type="checkbox"/> Municipal Retail License <input type="checkbox"/> State Permit	5. If successor agent, provide State Permit or Municipal Retail License Number N/A
6. Describe the reason for appointing a successor agent, if successor is checked above. N/A	

Part B: Agent Information

1. Last Name NAJERA	2. First Name BULFRANIO	3. M.I. C
4. Email	5. Phone	

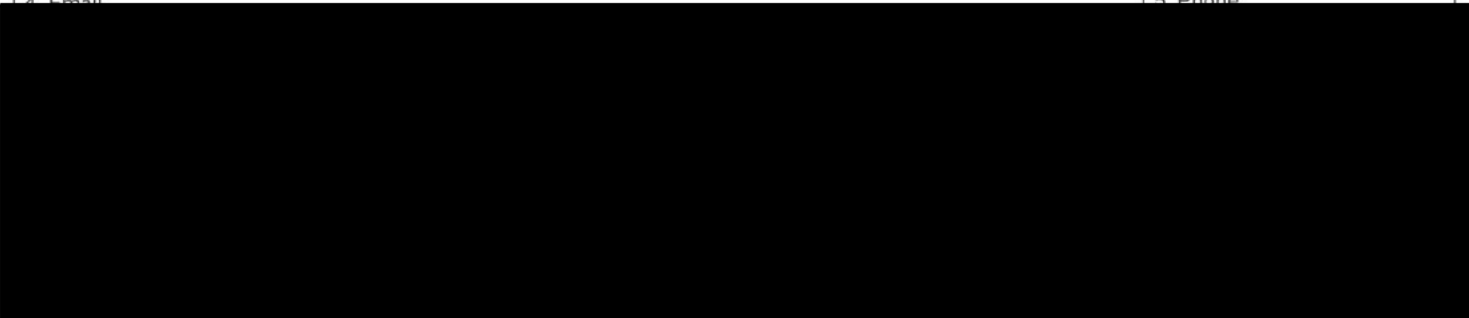

Part C: Agent Questions

1. Have you satisfied the responsible beverage server training requirement? Submit proof of completion.	<input checked="" type="checkbox"/> Yes <input type="checkbox"/> No
2. Have you completed Form AB-100, <i>Alcohol Beverage Individual Questionnaire</i> (licensee) or Form AB-300, <i>Alcohol Beverage Personal Questionnaire</i> (permittee)?	<input checked="" type="checkbox"/> Yes <input type="checkbox"/> No
3. Have you been a Wisconsin resident for at least 90 continuous days?..... See instructions for exceptions.	<input checked="" type="checkbox"/> Yes <input type="checkbox"/> No

Continued →

Part D: Business Attestation

READ CAREFULLY BEFORE SIGNING: I, the **Undersigned**, authorize the above-named individual to act for the above-named corporation, nonprofit organization, or limited liability company with full authority and control of the premises and of all alcohol beverage activities on such premises. I certify that I am authorized by the above-named entity to authorize this individual to act on behalf of the entity. If I am appointing a successor agent, I rescind all previous agent appointments for this premises. Further, I understand that I may be prosecuted for submitting false statements and affidavits in connection with this application, and that any person who knowingly provides materially false information on this application may be required to forfeit not more than \$1,000 if convicted.

Last Name NAJERA	First Name BULFRANO	M.I. C
Title	Email	Phone

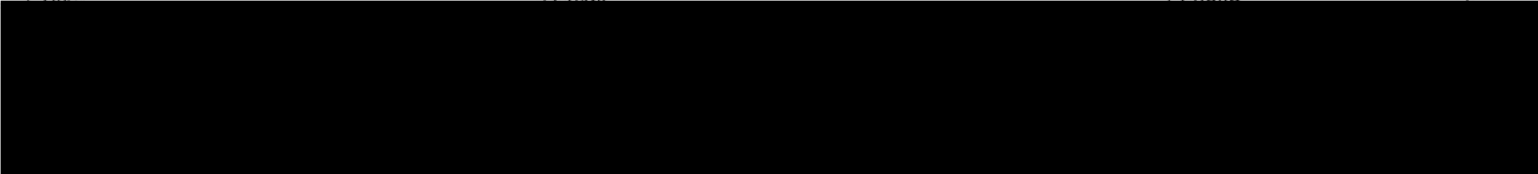

Part E: Agent Attestation

READ CAREFULLY BEFORE SIGNING: I, the **Agent**, hereby accept this appointment as agent for the above-named corporation, nonprofit organization, or limited liability company and assume full responsibility for the conduct of all alcohol beverage activities on the premises for the above-named business. I further understand that I may be prosecuted for submitting false statements and affidavits in connection with this application, and that any person who knowingly provides materially false information on this application may be required to forfeit not more than \$1,000 if convicted.

Last Name NAJERA	First Name BULFRANO	M.I. C
Signature 	Date 03/04/2025	



LEARN 2 SERVE™

CERTIFICATE OF COMPLETION

This certifies that

Bulfrano Najera

is awarded this certificate for

Wisconsin Responsible Beverage Server Training



Completion Date
02/10/2025



Expiration Date
02/10/2027



Certificate #
WI-00634528

Official Signature

This certificate is non-transferable and represents the successful completion of an approved Wisconsin Department of Revenue Responsible Beverage Server Course in compliance with secs. 125.04(5)(a)5., 125.17(6), and 134.66(2m), Wis. Stats.

Form
AB-100

Alcohol Beverage Individual Questionnaire

Date

All individuals involved in the alcohol beverage business must complete this form, including:

- sole proprietor
- all officers, directors, and agent of a corporation or nonprofit organization
- all partners of a partnership
- members and agent of a limited liability company

Your alcohol beverage application or renewal is not complete until all required Individual Questionnaires are submitted.

Part A: Business Information

1. Legal Business Name (individual name if sole proprietor) NAJERA BROTHERS COMPANY LLC	
2. Business Trade Name or DBA GENOAS PIZZA	
3. Entity Type (check one) <input type="checkbox"/> Sole Proprietor <input type="checkbox"/> Partnership <input checked="" type="checkbox"/> Limited Liability Company <input type="checkbox"/> Corporation <input type="checkbox"/> Nonprofit Organization	

Part B: Individual Information

1. Last Name NAJERA		2. First Name BULFRANO		3. M.I. C
4. Relationship to Business (Title) Co-owner		5. Email		6. Phone
7. Home Address 206 South State Street				
8. City Rochester		9. State WI	10. Zip Code 53167	11. Date of Birth 11/13/1997
12. Drivers License/State ID Number N260-0639-7413-09			13. Drivers License/State ID State of Issuance Wisconsin	

Part C: Address History

1. Do you currently live in Wisconsin? Yes No

If yes, provide the month and year when you permanently moved to Wisconsin (MM/YYYY) **01/1998**

2. List in chronological order all of your addresses within the last 5 years. Attach additional sheets if necessary.

[Redacted Address]			
Previous Address 2	City	State	Zip Code
Previous Address 3	City	State	Zip Code
Previous Address 4	City	State	Zip Code
Previous Address 5	City	State	Zip Code

3. List all states and counties you have lived in as an adult. Attach additional sheets if necessary.

State	County	State	County	State	County	State	County
WI	USA						
State	County	State	County	State	County	State	County

Continued →

Part D: Criminal History

1. Have you ever been convicted of any offenses (excluding traffic offenses unless related to alcohol beverages) for violation of any federal, Wisconsin, or another state's laws or of any county or municipal ordinances? Yes No

If yes to question 1, please list details of each conviction below. Attach additional sheets as needed.

Law/Ordinance Violated	Location	Conviction Date
Penalty Imposed		Was sentence completed? <input type="checkbox"/> Yes <input type="checkbox"/> No
Law/Ordinance Violated	Location	Conviction Date
Penalty Imposed		Was sentence completed? <input type="checkbox"/> Yes <input type="checkbox"/> No
Law/Ordinance Violated	Location	Conviction Date
Penalty Imposed		Was sentence completed? <input type="checkbox"/> Yes <input type="checkbox"/> No

2. Are charges for any offenses currently pending against you (excluding traffic offenses unless related to alcohol beverages) for violation of any federal, Wisconsin, or another state's laws or any county or municipal ordinances? Yes No

If yes to question 2, describe nature and status of pending charges using the space below. Attach additional sheets as needed.

Part E: Attestation

READ CAREFULLY BEFORE SIGNING: Under penalty of law, I have answered each of the above questions completely and truthfully. I certify that I am not prohibited from participating in this business due to any involvement in another tier of the alcohol beverage industry as a restricted investor. I understand that any license issued contrary to Wis. Stat. Chapter 125 shall be void under penalty of state law. I further understand that I may be prosecuted for submitting false statements and affidavits in connection with this application, and that any person who knowingly provides materially false information on this application may be required to forfeit not more than \$1,000 if convicted.

Signature



Date

03/04/2025

Application for Temporary Class "B" / "Class B" Retailer's License

PAID
CK NO _____
DATE _____

See Additional Information on reverse side. Contact the municipal clerk if you have questions.

FEE \$ 40- Application Date: _____
 Town Village City of Mukwonago County of WAUKESHA

The named organization applies for: (check appropriate box(es).)

- A Temporary Class "B" license to sell fermented malt beverages at picnics or similar gatherings under s. 125.26(6), Wis. Stats.
- A Temporary "Class B" license to sell wine at picnics or similar gatherings under s. 125.51(10), Wis. Stats.

at the premises described below during a special event beginning _____ and ending _____ and agrees to comply with all laws, resolutions, ordinances and regulations (state, federal or local) affecting the sale of fermented malt beverages and/or wine if the license is granted.

1. Organization (check appropriate box) → Bona fide Club Church Lodge/Society
 Veteran's Organization Fair Association or Agricultural Society
 Chamber of Commerce or similar Civic or Trade Organization organized under ch. 181, Wis. Stats.

(a) Name AMERICAN LEGION Post # 375

(b) Address 627 E. VETERAN'S WAY Mukwonago WI 53149
(Street) Town Village City

(c) Date organized 1934

(d) If corporation, give date of incorporation _____

(e) If the named organization is not required to hold a Wisconsin seller's permit pursuant to s. 77.54 (7m), Wis. Stats., check this box:

(f) Names and addresses of all officers:

President _____
Vice President Timothy J. Flury 1242 River Park Cir. W. Mukwonago 53149
Secretary _____
Treasurer _____

(g) Name and address of manager or person in charge of affair: SAME AS (F) ABOVE

2. Location of Premises Where Beer and/or Wine Will Be Sold, Served, Consumed, or Stored, and Areas Where Alcohol Beverage Records Will be Stored:

(a) Street number FIELD PARK

(b) Lot _____ Block _____

(c) Do premises occupy all or part of building? _____

(d) If part of building, describe fully all premises covered under this application, which floor or floors, or room or rooms, license is to cover: _____

3. Name of Event

(a) List name of the event MAXWELL STREET DAYS

(b) Dates of event JUNE 7-8, JULY 19-20, AUG 16-17, SEPT 13-14

DECLARATION

An officer of the organization, declares under penalties of law that the information provided in this application is true and correct to the best of his/her knowledge and belief. Any person who knowingly provides materially false information in an application for a license may be required to forfeit not more than \$1,000.

Officer _____
(Signature / Date)

(Name of Organization)

Date Filed with Clerk _____

Date Reported to Council or Board _____

Date Granted by Council _____

License No. _____

Application for Temporary Class "B" / "Class B" Retailer's License

See Additional Information on reverse side. Contact the municipal clerk if you have questions.

FEE \$ 30

Application Date: 2/20/2025

Town Village City of MUKWONAGO

County of WAUKESHA

The named organization applies for: (check appropriate box(es).)

A Temporary Class "B" license to sell fermented malt beverages at picnics or similar gatherings under s. 125.26(6), Wis. Stats.

A Temporary "Class B" license to sell wine at picnics or similar gatherings under s. 125.51(10), Wis. Stats.

at the premises described below during a special event beginning JUNE and ending SEPTEMBER and agrees to comply with all laws, resolutions, ordinances and regulations (state, federal or local) affecting the sale of fermented malt beverages and/or wine if the license is granted.

1. Organization (check appropriate box) →

- Bona fide Club Church Lodge/Society
 Veteran's Organization Fair Association or Agricultural Society
 Chamber of Commerce or similar Civic or Trade Organization organized under ch. 181, Wis. Stats.

(a) Name ROTARY CLUB OF MUKWONAGO

(b) Address P.O. Box 114, MUKWONAGO, WI 53149
(Street) Town Village City

(c) Date organized MAY 1990

(d) If corporation, give date of incorporation _____

(e) If the named organization is not required to hold a Wisconsin seller's permit pursuant to s. 77.54 (7m), Wis. Stats., check this box:

(f) Names and addresses of all officers:

President SHAWN McMULTY

Vice President _____

Secretary TOM HERLUGSON

Treasurer JIM COTTURONE

(g) Name and address of manager or person in charge of affair: JERRY PEIFFER

2. Location of Premises Where Beer and/or Wine Will Be Sold, Served, Consumed, or Stored, and Areas Where Alcohol Beverage Records Will be Stored:

(a) Street number PHANTOM JUNCTION STAGE AREA

(b) Lot _____ Block _____

(c) Do premises occupy all or part of building? NO

(d) If part of building, describe fully all premises covered under this application, which floor or floors, or room or rooms, license is to cover: IN THE AREA NEAR THE STAGE THE ROTARY CLUB WILL SET UP A 10' X 20' (APPROX) STAND WITH CANOPY

3. Name of Event

(a) List name of the event PHANTOM STAGE CONCERTS

(b) Dates of event 7/3/25; 8/9/25; 9/20/25

DECLARATION

An officer of the organization, declares under penalties of law that the information provided in this application is true and correct to the best of his/her knowledge and belief. Any person who knowingly provides materially false information in an application for a license may be required to forfeit not more than \$1,000.

Officer Shawn McMulty 2/20/25
(Signature / Date)

ROTARY CLUB OF MUKWONAGO
(Name of Organization)

Date Filed with Clerk _____

Date Reported to Council or Board _____

Date Granted by Council _____

License No. _____

VILLAGE OF MUKWONAGO
440 RIVER CREST CT
MUKWONAGO, WI 53149
Phone : (262) 363-6420

Received From: ROTARY CLUB
Date: 03/25/2025
Receipt: 93652 *** REPRINT ***
Cashier: SZERFAS
Time: 3:49:20 PM

PJS VENDOR 2025 & LIQUOR LIC X3

ITEM REFERENCE	AMOUNT
125 Special Event Permit	
PJS VENDOR 3 EVENTS	\$300.00
118 Liquor & Malt License	
LIQUOR LICENSE X3 PICNIC	\$30.00
TOTAL	\$330.00
Check 1418	\$330.00
Total Tendered:	\$330.00
Change:	\$0.00



Mukwonago Professional Firefighters

IAFF Local 4585

1111 Fox St Mukwonago, WI 53149

March 6, 2025

Kathy Karalewitz
Town of Mukwonago
Administrator, Clerk/Treasurer
W320 S8315 Beulah Road
Mukwonago, WI 53149

Lana C Kropf
Village of Mukwonago
Clerk/Treasurer
440 Rivercrest Ct
Mukwonago, WI 53149

Dear Kathy Karalewitz and Lana Kropf,

I am writing to formally initiate discussions regarding negotiations of the Mukwonago Professional Firefighters contract that is set to expire December 31st 2025. Please inform us of a convenient date to arrange a meeting for this purpose.

I would like to formally request that this item be placed on the next Joint Protective Services agenda so that the municipalities can conduct business related to the above item.

I will await your response.

Sincerely,

Lindsey Fickau
President
Mukwonago Professional Firefighters
IAFF Local 4585
lfickau@mukwonagofire.org
262.424.4269

THE DIRECTOR'S REPORT

MARCH 2025

MUKWONAGO COMMUNITY LIBRARY

reflections on February

*from the desk of
Abby Armour*

NEWS YOU CAN USE

Each year I attend **Library Legislative Day** to advocate to our state legislators about the importance of libraries and encourage them to continue to fund library systems well in the biennial state budget. This year I brought along Associate Director James Pride as well as homeschool dad Matt DeMarais with his 7th grade son Joe. Their presence was invaluable, as it allowed legislators to hear directly from library users about the vital role our library plays in their lives. These personal stories

from community members create powerful connections that statistics alone cannot achieve. Advocacy isn't just for library professionals—it's for everyone who values these community hubs!



Fiber optic cables being laid underground on the south side of the building

STRATEGIC PLAN

Renovation Feasibility Study

To fulfill our goal of "providing a variety of age-appropriate and accessible spaces", we've made significant progress on the Feasibility Study. The steering committee has met twice and Library Strategies is preparing a case presentation. We're scheduling donor interviews to gather feedback and explore funding opportunities. This professional approach will provide a solid foundation for ensuring this project is properly promoted and funded.

Automated Materials Handler Research

I completed research visits to five libraries and presented findings to the Building & Grounds Committee. I'm now securing vendor cost estimates for technologies that will help "users find and get what they need faster and more efficiently." This work precedes renovations to ensure the design properly accommodates these technological improvements.

Fiber Optic Installation

As part of our commitment to "work in partnership with the Village to ensure Library improvements fulfill mutual goals", fiber optic cables were buried and run into our server closet. This collaborative effort supports the Village's infrastructure project while simultaneously improving our VOIP phone system stability—all at no cost to the Library.

BY THE NUMBERS: FEBRUARY 2025

46,950

Total 2025
physical + digital circulation
+1.2% compared to 2024



18,891

physical item circulation
in February
-1% compared to 2024

3,784

digital item circulation
in February
+6.1% compared to 2024



Note: The Bridges Library System has invested heavily in building up the system's Lucky Day collection in Overdrive/Libby. And our users are checking out a LOT more because of it!



1,806

items circulated through
the smartlockers in January
+74.7% compared to 2024

553

community members
used our rooms
in January
+73.7% compared to 2024



415

new items added
in January
-15% compared to 2024

18,144

Total 2025
visits to the Library
+4% compared to 2024

88

new library cards
in February
-24% compared to 2024



1,087

people attended
programs in February
+3.4% compared to 2024

COLLECTIONS & PROGRAMS TEAM

Our Thingery's refocus around our vision statement has brought specialized resources that genuinely enhance lives and meet real community needs.

Our **Stay Sharp Kits** have been incredibly popular, circulating 15 times in just a couple months! These specialized kits offer theme-based books and engaging activities like puzzles and card games designed for people experiencing memory loss or cognitive challenges, while also benefiting anyone looking to improve mental agility.



We're excited to introduce our newest addition to The Thingery Jr.—the **Dyslexia Support Kit**. This resource was curated by Youth Services Librarian Jane DeAngelis and includes a digital pen that reads text aloud, reading guide strips, and other helpful tools specifically designed for families supporting children with dyslexia.

THE THINGERY JR

Dyslexia Support Kit



- Includes:
- IrisPen Reader
 - Focus Finger highlighter wands
 - Reading guide strips
 - Colored visual stress overlays
 - Book: Learn to Read For Kids with Dyslexia
 - Workbook: Dyslexia Workbook for Kids



THE DIRECTOR'S REPORT

Mukwonago Community Library
Mar. 2025 - Reflections on Feb.

CIRCULATION & CUSTOMER EXPERIENCE TEAM

Pantheon Industries, a workforce development group, partnered with us to place their client **Lilly** here to learn Library Page duties with our staff and her job coaches. This collaboration demonstrates how our Library supports **workforce development** while creating meaningful opportunities in our community.



In March, we're launching **LX Starter** for **patron notifications**, featuring user-friendly hold notices and overdue reminders. New notices will include book cover images—a frequently requested feature. Thanks to Circulation Specialist Fiehweg and Marketing & Outreach Specialist Plitzner for their work on this project and the Library Board Trustees, MCL staff, and Library super users for their valuable feedback during development. We're excited to enhance patron communication!

Our fantastic 14-member Circulation and Customer Experience team just finished their **Periodic Evaluations!** These 30-minute sessions are a valuable way to address challenges, celebrate success, and exchange feedback. We're impressed by our staff's dedication to our Library!

THE DIRECTOR'S REPORT

Mukwonago Community Library
Mar. 2025 – Reflections on Feb..

PROGRAMS

“Waika: Native American Storytelling with White Winnebago” captivated our community last month as Gerald Savage delivered an educational and entertaining presentation on the Ho-Chunk storytelling tradition. The event drew an impressive crowd of **50 attendees** who were so engaged that the program extended well beyond its scheduled time. Due to the overwhelming interest and enthusiasm, we're delighted to announce that we've scheduled Gerald to return in November for one of his popular history presentations!



Thanks to Library Board Trustee Michelle Oberwise-Lacock for introducing us to Gerald Savage and recommending his programs!

We have once again partnered with **AARP** to provide free tax preparation for seniors in our community.



This mutually beneficial collaboration allows AARP to supply the tax specialists while we manage all scheduling. This year, AARP offered an impressive 40 slots per day every Monday from February 3 through April 7. By the end of February, all appointments were completely booked, serving **394 community members**. As the only free tax service available to many in our area, we continue to serve as a vital resource for residents living on fixed pensions or with limited incomes.

METASPACE 511

Our MetaSpace 511 classes continue to be in high demand—often filling to capacity through our online reservations. This month's standout, **Laser Cut Wood & Resin Jewelry**, taught participants the intricate process of creating unique pieces using our laser machine and UV resin. Lead Innovator Nancy Aycok commented on the nature of offering an exciting specialty class: "I had four classes with 5 people each. This has been one of the smaller classes that I've had due to equipment, supplies, and technique. Maker In Residence Cameron is running two encore classes this month as Pop-Ups for people who couldn't get into the other four classes."



The MetaSpace got a much-needed upgrade this month: **a bigger sink!** Thanks to a generous donation, we collaborated with the Village DPW to install the largest sink possible, instantly improving our capacity and adding a new removable sprayer for easier cleanup.



AROUND THE LIBRARY

"I often travel to Chicago and don't always know if I will be back in time to make it during open library hours, so these lockers have been amazing to ensure I always can access my holds!"

- a library user commenting on the smartlockers that offer 24/7 holds pickup

MARK YOUR CALENDARS

Our programming team is collaborating more closely than ever, developing cohesive monthly themes that unite our diverse offerings into exciting, integrated experiences.



Anchored by the monthlong **"Warrior Ink"** exhibit on loan from Menomonee Falls Public Library and featuring Mukwonago resident Chris Flury, our March programming honors veterans through diverse offerings—from exploring military canine service in **"War Dogs"** to discovering the rich history and **cultural significance of tattoos** during author Amelia Osterud's engaging presentation.

Scan the QR code for the March event calendar



THE DIRECTOR'S REPORT

Mukwonago Community Library
Mar. 2025 - Reflections on Feb.



ABBY ARMOUR LIBRARY DIRECTOR

aarmour@mukwonagolibrary.org
(262) 363-6411 ext. 4100

The building is deteriorating due to moisture, ill advised patches, and the nature of the log design itself but has been deemed “saveable” by Alan Pape of Old World Wisconsin fame.



ALAN PAPE

President

Alan was born in Milwaukee and as a kid spent many hours at the old Milwaukee Natural History Museum and at the Milwaukee Boys Club where he discovered the fascinating world of log buildings. He participated in the Club's "Tour Camping" programs where he visited every state park and nearly every roadside historical marker in Wisconsin. He received his degree in landscape architecture from the University of Wisconsin specializing in Historic Preservation. He was an employee of the Wisconsin Historical Society for 15 years while helping to build Old World Wisconsin. He was also the Site Manager for the Wade House historic site in Greenbush for four years.

In simplest terms, repair involves sealing the current logs, patching some, and applying wavy beveled siding over vertical furring strips. This will protect the logs from further deterioration but retain a rough-hewn appearance to the trading post. This siding was sometimes applied over log structures in the 19th century. The original structure was undoubtedly square hewn logs that shed moisture, not the “Wilderness” design.



Why is this building important to Mukwonago and its visitors?

- ***The Historical Society uses the building to tell the story of the Andrews' trading post, the only source of supplies to local settlers in the beginning of the village. It was THE only commercial center within a radius of 15 miles in the 1830's. From the memoirs of Wilder Howard, a boy who worked for Andrews, we know the store was a log structure that once stood on the site. Revenue from this store funded the construction of the first brick home in Waukesha County in 1842.***
- ***The interior depicts the trading post genre, serves as a gift shop, and is used for events such as our ice cream social. The gift shop is currently a nominal revenue generator but with a broader offering, such as artisan cheeses, it can become a greater source of revenue. Requires electrification. (Lighting and refrigeration.)***

The Trading Post is a symbolic representation of Mukwonago as an early commerce center.



Friends of the Saxonia House Inc



ALAN PAPE
President

Alan was born in Milwaukee and as a child spent many hours at the old Milwaukee Natural History Museum and at the Milwaukee Zoo. He has been instrumental in the founding of the "Caring" program where he visited every state park and nearly every notable historic landmark in Wisconsin. He received his degree in Landscape Architecture from the University of Wisconsin, working in historic preservation.

Learn more about the history of the Wisconsin Historical Society while helping to preserve our state's heritage. Visit us at the Tower Heritage Center.

SAXONIA HOUSE
A FUTURE ARTIST
RETREAT CENTER



ALAN C. PAPE
314 Commerce Street
West Bend, WI 53090 USA
office: 920-526-3433
cell: 920-889-1329
alan85@aol.com
www.saxoniahouse.org



MHMS representatives met with experts on early Wisconsin structures on September 24th.

The building is deteriorating due to moisture, ill advised patches, and the nature of the log design itself but has been deemed “saveable” by Alan Pape of Old World Wisconsin fame.



ALAN PAPE

President

Alan was born in Milwaukee and as a kid spent many hours at the old Milwaukee Natural History Museum and at the Milwaukee Boys Club where he discovered the fascinating world of log buildings. He participated in the Club's "Tour Camping" programs where he visited every state park and nearly every roadside historical marker in Wisconsin. He received his degree in landscape architecture from the University of Wisconsin specializing in Historic Preservation. He was an employee of the Wisconsin Historical Society for 15 years while helping to build Old World Wisconsin. He was also the Site Manager for the Wade House historic site in Greenbush for four years.

In simplest terms, repair involves sealing the current logs, patching some, and applying wavy beveled siding over vertical furring strips. This will protect the logs from further deterioration but retain a rough-hewn appearance to the trading post. This siding was sometimes applied over log structures in the 19th century. The original structure was undoubtedly square hewn logs that shed moisture, not the “Wilderness” design.



The Wavy Board Siding would simulate the square hewn logs of the original Trading Post.



The Building is sound structurally and the underside is pristine as verified by visual inspection.

This is a Win-Win for the Museum & Village. Per our Lease, we ask for Board Approval

- ***Restoration method will extend the life of the existing building by 25-30 years.***
- ***Village expends no capital in 2026 for a new building.***
- ***Eliminates the uncertainty of the capital ever being spent. The building needs help NOW! (No risk of “DOGE”)***
- ***With completion this spring, we avoid further material cost escalation.***
- ***With electrical service in the building, the Society can expand gift shop offerings to increase supporting revenue.***

***The Trading Post Story Lives on
For our Visitors...Especially the Kids!***



Help Save the Log Cabin Trading Post!

Join the effort to preserve this iconic Mukwonago cabin!

This fifty-plus-year-old structure, gifted to the Village in 1982, has been used by the Mukwonago Historical Society as a symbolic representation of the log cabin trading post owned by village founder Sewall Andrews in the late 1830's and 1840's. The structure exhibits the "Wilderness" style of round log construction popular in the "frontier revival" period of the 1950's and 1960's. Since its move to the site, it has received little maintenance save for the new roof about 10 years ago and is in need of significant repair due to extensive log rot, particularly on the west and north sides.



DONATE TODAY!

March 21, 2025

Ms. Diana Dykstra, ICMA-CM, MMC
 Administrator
 Village of Mukwonago
 440 River Crest Court
 Mukwonago, Wisconsin 53149

RE: Field Park Pickleball Court

Dear Ms. Dykstra:

Bids for the above project were opened on March 20, 2025, at 10:00 a.m. at the Village Hall and were as follows:

	BIDDER	BASE BID	MANDATORY ALTERNATE
1.	Parking Lot Maintenance, LLC	\$132,894.48	\$34,299.14
2.	Wolf Paving Co., Inc.	\$174,015.50	\$39,468.00
3.	Poblocki Paving Corporation	\$209,298.00	\$55,904.00

We reviewed the documentation submitted by the apparent low bidder and found that:

1. The Bid Form has been appropriately completed.
2. We have no objections to the low bidder, nor to the proposed major subcontractors and suppliers.
3. Low bidder has successfully completed similar projects.

On these bases, we recommend that Parking Lot Maintenance, LLC be awarded the Field Park Pickleball Court contract, in the amount of \$132,894.48. This amount is based on the bid unit prices and estimated quantities. Actual quantities, and therefore the final contract price, may vary. On all construction projects unpredictable factors may increase the final contract amount. For this reason, we recommend that the Village include a 10 percent contingency when preparing the financial plan for this work.

Our review did not include an evaluation of bidder's current financial condition nor of their permanent safety program.

Should you decide to accept our recommendation, we have prepared the enclosed Notice of Award for your use. After Board approval has been received, please have the appropriate official sign where indicated and forward a signed copy of the Notice of Award to our office. We will then fill in the date at the top of page one and forward it, with contracts for execution, to the Contractor. One fully completed Notice of Award will be returned to you for your records.

Ms. Diana Dykstra, ICMA-CM, MMC
Village of Mukwonago
March 21, 2025
Page 2

Bids remain subject to acceptance until May 19, 2025, unless Bidder agrees to an extension. Please advise us of your award decision, or call if there are any questions.

Respectfully,

RUEKERT & MIELKE, INC.

Michael E. Michalski
Project Engineer
mmichalski@ruekert-mielke.com

MEM:sjs

Encl: Notice of Award
Bid Tabulation

cc: Ron Bittner, Village of Mukwonago
Lana Kropf, Village of Mukwonago
Diana Doherty, Village of Mukwonago

NOTICE OF AWARD

Date of Issuance: _____

Contract: Field Park Pickleball Court	Owner:	Village of Mukwonago
Bidder: Parking Lot Maintenance, LLC	Engineer:	Ruekert & Mielke, Inc.
Address: W225 N3178 Duplainville Road Pewaukee, WI 53072	Engineer's Project No.:	12-10232.200

TO BIDDER:

You are notified that your Bid dated March 20, 2025 for the above Contract has been accepted by Owner and you are the Successful Bidder and are awarded a Contract for:

Field Park Pickleball Court Base Bid

The Contract Price of your Contract is: \$ 132,894.48

Two (2) copies of the proposed Contract Documents (except Drawings) accompany this Notice of Award or have been transmitted or made available to Bidder electronically.

Two (2) sets of the Drawings will be delivered separately or otherwise made available to Bidder electronically.

Bidder must comply with the following conditions precedent within 15 days of the date of issuance of this Notice of Award:

1. Deliver to Engineer one (1) fully executed counterparts of the Contract Documents.
2. Deliver with the executed Agreement the Performance Bond, Payment Bond as specified in the Instructions to Bidders (Article 21), General Conditions (Paragraph 6.01).
3. Deliver with the executed Agreement certificates and other evidence of insurance as specified in the General Conditions (Article 6) and the Supplementary Conditions modifying Article 6 of the General Conditions.

Failure to comply with these conditions within the time specified will entitle Owner to consider you in default, annul this Notice of Award, and declare your Bid security forfeited.

Within 10 days after you comply with the above conditions, Engineer will return to you one fully executed counterpart of the Agreement.

Owner: Village of Mukwonago

Signature: _____
Authorized Signature

Title: _____

Date: _____

Copy: Engineer

COST COMPARISON OF BIDDERS

OWNER: Village of Mukwonago
PROJECT: Field Park Pickleball Court
BID OPENING DATE: March 20, 2025

BASE BID				Parking Lot Maintenance, LLC		Wolf Paving Co., Inc.		Poblocki Paving Corporation	
ITEM #	ITEM DESCRIPTION	UNIT	QTY.	UNIT \$	TOTAL	UNIT \$	TOTAL	UNIT \$	TOTAL
1	Mobilization	L.S.	1	\$6,068.00	\$6,068.00	\$21,906.00	\$21,906.00	\$2,000.00	\$2,000.00
2	Remove existing fencing	L.F.	360	\$13.08	\$4,708.80 *	\$15.00	\$5,400.00	\$14.00	\$5,040.00
3	Remove existing pavement	S.Y.	670	\$5.35	\$3,584.50	\$8.00	\$5,360.00	\$7.00	\$4,690.00
4	Construct pickleball court to subgrade	L.S.	1	\$9,655.00	\$9,655.00	\$14,500.00	\$14,500.00	\$6,222.00	\$6,222.00
5	Grade, shape, and compact pickleball court base	L.S.	1	\$1,500.00	\$1,500.00	\$13,150.00	\$13,150.00	\$6,588.00	\$6,588.00
6	Construct multi-use path to subgrade	L.S.	1	\$3,180.00	\$3,180.00	\$7,125.00	\$7,125.00	\$10,102.00	\$10,102.00
7	Concrete edging	L.F.	388	\$53.68	\$20,827.84	\$32.00	\$12,416.00	\$112.00	\$43,456.00
8	2-1/2 inch Asphaltic concrete binder course	TON	130	\$104.50	\$13,585.00	\$125.00	\$16,250.00	\$174.00	\$22,620.00
9	1-1/2 inch Asphaltic concrete surface course	TON	78	\$137.00	\$10,686.00	\$185.00	\$14,430.00	\$202.00	\$15,756.00
10	3-inch Asphaltic concrete multi-use path	TON	28	\$133.21	\$3,729.88	\$179.50	\$5,026.00	\$202.00	\$5,656.00
11	Galvanized chain link fence, 10' height	L.F.	388	\$68.25	\$26,481.00	\$67.00	\$25,996.00	\$101.00	\$39,188.00
12	Galvanized chain link fence, 4' height	L.F.	54	\$63.00	\$3,402.00	\$53.50	\$2,889.00	\$110.00	\$5,940.00
13	Galvanized chain link fence gate, 8' height x 4' wide.	EA.	1	\$1,785.00	\$1,785.00	\$550.00	\$550.00	\$1,078.00	\$1,078.00
14	Electrical conduit assembly	EA.	6	\$272.00	\$1,632.00	\$250.00	\$1,500.00	\$366.00	\$2,196.00
15	Pickleball court color surfacing	S.Y.	854	\$16.99	\$14,509.46	\$17.50	\$14,945.00	\$20.00	\$17,080.00
16	Pickleball court net assembly	EA.	4	\$787.50	\$3,150.00	\$2,360.00	\$9,440.00	\$3,584.00	\$14,336.00
17	Topsoil, turf grass seed, fertilizer, tackifier Type B, and mulch	S.Y.	350	\$12.60	\$4,410.00	\$8.95	\$3,132.50	\$21.00	\$7,350.00
TOTAL OF ALL ESTIMATED PRICES (ITEMS 1 - 17)					\$132,894.48		\$174,015.50		\$209,298.00
Mandatory Alternate									
MA-1	Black vinyl coated chain link fence, 10' height	L.F.	388	\$74.03	\$28,723.64	\$91.00	\$35,308.00	\$122.00	\$47,336.00
MA-2	Black vinyl coated chain link fence, 4' height	L.F.	54	\$68.25	\$3,685.50	\$60.00	\$3,240.00	\$130.00	\$7,020.00
MA-3	Black vinyl coated chain link fence gate, 8' height x 4' wide	EA.	1	\$1,890.00	\$1,890.00	\$920.00	\$920.00	\$1,548.00	\$1,548.00
TOTAL OF ALL MANDATORY ALTERNATE ESTIMATED PRICES (ITEMS MA-1 - MA-3)					\$34,299.14		\$39,468.00		\$55,904.00
TOTAL OF ALL ESTIMATED PRICES					\$167,193.62		\$213,483.50		\$265,202.00

* Parking Lot Maintenance, Bid Item No. 2
Should be \$4,708.80

TASK ORDER

This is Task Order No. 2025-04,
consisting of 4 pages.
Village of Mukwonago
East Wolf Run Extension

Task Order

In accordance with the Agreement Amendment between Village of Mukwonago (Owner) and Ruekert & Mielke, Inc. (Engineer) dated December 21, 2022, Owner and Engineer agree as follows:

1. Specific Project Data

- A. Title: East Wolf Run Extension
- B. Description: Provide engineering and construction related services for the design, bidding, and construction of the extension of East Wolf Run.

2. Services of Engineer

Perform certified survey mapping, design services, bidding support, and construction-related services for the extension of East Wolf Run. The scope of work includes a detailed topographic survey and the engineering design of approximately 420 linear feet of roadway improvements. These improvements will include pedestrian access and the design of a bridge crossing over the existing creek.

Phase 200 – Design and Bidding:

- Prepare and coordinate overall project schedule,
- Perform site topographic survey,
- Perform and process drone survey and aerial photography,
- Geotechnical investigations,
- Easements, title searches and other property acquisition services,
- Environmental assessment,
- Certified Endangered Resources Investigations,
- Facilitate 60% design meeting with Village staff and Mr. Greenwald,
- Facilitate 90% design meeting with Village staff and Mr. Greenwald,
- Prepare plan and profile set of drawings along the centerline alignment for proposed storm sewer and bridge crossing,
- Prepare plan and profile drawings along the proposed centerline alignment for proposed roadways, includes cross-sections plan of drawings,
- Prepare plan of drawing for intersection detail of the roundabout,
- Prepare plan of drawings for erosion control,
- Prepare plan of drawings for construction details and construction notes,
- Floodplain analysis and approvals,
- WDNR Chapter 30 General permitting,
- ACOE permitting,
- DNR NOI,
- Prepare project specifications and other bidding documents,
- Prepare Advertisement for Bids,
- Upload bidding documents for online viewing/ordering,
- Answer Contractor questions during bidding period,
- Attend Bid Opening,
- Review bids for completion of all contract requirements. Review prequalification statements, and bidder references,
- Issue Recommendation of Award and Notice of Award,
- Attend Village Board meeting to answer questions about the award of the project.

TASK ORDER

Phase 320 – Construction Review and Contract Administration Services

- Provide construction review services,
- Administer the construction contract between the Owner and the Contractor. Duties to be performed are itemized in the Construction Contract between the Owner and the Contractor,
- Respond to Owner staff requests for information,
- Quantity measurements and quantity coordination with Contractor,
- Coordinate pay request with Owner Staff,
- Coordinate and attend pre-construction meeting,
- Coordinate and attend weekly site meetings,
- Respond to citizen questions during construction,
- Final project closeout.

Work Available as Additional Services:

The following services are not included in this effort because we have assumed they are not necessary, or the scope of such services has not yet been defined:

- Wetland delineations,
- Archaeological survey,
- Funding requirements,
- Permit applications not listed,
- Public Information Meetings.

3. Owner's Responsibilities

The Village will Coordinate with Ruekert & Mielke staff to review draft plans, meet onsite to review layout and attend bid opening. Owner will pay for the cost of advertisement, Engineer's reimbursable expenses, reproduction of the bidding documents, distribution of the bidding documents, and will refer all bidders' questions to the Engineer for response.

4. Times for Rendering Services

<u>Phase</u>	<u>Completion Date</u>
Advertisement for Bid	January 8, 2026
Bid Opening	January 22, 2026
Recommendation of Award	February 4, 2026

5. Payments to Engineer

A. Owner shall pay Engineer for services rendered as follows:

<u>Category of Services</u>	<u>Compensation Method</u>	<u>Estimate of Compensation for Services</u>
Design and Bidding	Lump Sum	\$65,450
Construction Review and Contract Administration Services	Hourly	\$ 54,170*

* Services and cost are directly related to the amount of time the selected Contractor takes to complete the project.

The terms of payment are set forth in the Standard Terms and Conditions.

TASK ORDER

6. Consultants:

Intertek PSI Geotechnical Engineering Services.

7. Other Modifications to Standard Terms and Conditions:

None.

8. Attachments:

Level of Effort Breakdown for Services and Engineer's Estimated Construction Cost.

9. Documents Incorporated by Reference

Ruekert & Mielke, Inc. / Village of Mukwonago Master Agreement.

TASK ORDER

Task Order No. 2025-04
EAST WOLF RUN EXTENSION
Between Village of Mukwonago
and
Ruekert & Mielke, Inc.
Dated March 24, 2025

Terms and Conditions: Execution of this Task Order by Owner and Engineer shall make it subject to terms and conditions, (as modified above) set forth in the Master Engineering Agreement between Owner and Engineer, dated December 21, 2022, which are incorporated by this reference. Engineer is authorized to begin performance upon its receipt of a copy of this Task Order signed by Owner.

The Effective Date of this Task Order is _____, _____.

OWNER:	ENGINEER:
Village of Mukwonago	Ruekert & Mielke, Inc.
Signature: _____	Signature: _____
Name: _____	Name: <u>Jason P. Lietha, P.E</u>
Title: _____	Title: <u>Senior Vice President</u>
Date: _____	Date: <u>March 24, 2025</u>

DESIGNATED REPRESENTATIVE FOR TASK ORDER

Name: _____	Name: <u>Michael E. Michalski</u>
Title: _____	Title: <u>Project Engineer</u>
Address: _____ _____	Address: <u>W233 N2080 Ridgeview Parkway</u> <u>Waukesha, WI 53188-1020</u>
Email: _____	Email: <u>mmichalski@ruekert-mielke.com</u>
Phone: _____	Phone: <u>262-953-3004</u>
Fax: _____	Fax: <u>262-542-5631</u>

East Wolf Run Extension

Design and Bidding Estimate

	Peter Gesch	Michael Michalski	Daniel Schwartz	Drafting	Sue Shird	Ecologist / Biologist	Professional Land Surveyor	Survey	Other Expenses	
Initials	PWG	MEM	DJS		SJS					
Employee Class	E5	E4	E4	ET-3	AA	AHH	PLS	Crew		Task Total
Hourly Rates	\$ 195	\$ 175	\$ 184	\$ 149	\$ 95	\$ 160	\$ 171	\$ 267		Dollars
Field Survey										
Perform Site Survey			4					10	\$450	\$ 3,856
Create project in Cad, Format Drawing, Call Diggers, Prep Data for Field Crew, Instructions							6			\$ 1,026
Process Downloads, Analyze Data, Build Surface and Cadastral Easement document, title searches and other property acquisition services			10					1		\$ 2,107
							24	3	\$300	\$ 5,205
Environmental										
Environmental assessment						6				\$ 960
Certified Endangered Resources Review						6				\$ 960
Geotechnical services									\$5,000	\$ 5,000
Design										
Prepare and coordinate overall project schedule and route		6		3						\$ 1,497
Surface, planimetric and profile creation				6						\$ 894
Prepare plan and profile set of drawings along the centerline alignment for proposed storm sewer and bridge crossing		16		12						\$ 4,588
Prepare plan and profile drawings along the proposed centerline alignment for proposed roadways, includes cross-sections plan of drawings		12		24						\$ 5,676
Prepare intersection detail of the roundabout		4		8						\$ 1,892
Prepare plan of drawings for erosion control		3		9						\$ 1,866
Prepare plan of drawings for construction details and construction notes		4		8						\$ 1,892
Floodplain analysis and approvals		3				16				\$ 3,085
Prepare project specifications and other bidding documents		32			14					\$ 6,930
60% Design Review										
Village of Mukwonago & Mr. Greenwald Review		6		3						\$ 1,497
90% Design Review										
Village of Mukwonago & Mr. Greenwald Review		6		3						\$ 1,497
100% Design Review										
Internal Quality Control Review	6			3						\$ 1,617
Approvals - Regulatory Agencies										
WDNR Chapter 30 General permitting		6				36				\$ 6,810
U.S. Army Corps of Engineer						8				\$ 1,280
WDNR NOI Permit						12				\$ 1,920
Bidding										
Prepare Advertisement for Bids		2			4				\$600	\$ 1,330
Upload bidding documents for online viewing/ordering					1					\$ 95
Answer Contractor questions during bidding period		2								\$ 350
Attend Bid Opening		2								\$ 350
Evaluate Bids, Prepare Bid Tab		1			4					\$ 555
Assist Village with Contractor References		1								\$ 175
Prepare Recommendation for Award		2			2					\$ 540
Survey, Design and Bidding Phase Subtotal (Hours) =	6	108	14	79	25	84	30	14		
Survey, Design and Bidding Phase Subtotal (Dollars) =	\$ 1,170	\$ 18,900	\$ 2,576	\$ 11,771	\$ 2,375	\$ 13,440	\$ 5,130	\$ 3,738	\$ 6,350	\$ 65,450

East Wolf Run Extension

Construction Related Services Estimate

	Michael Michalski	Construction	Erosion CRT	Professional Land Surveyor	Survey Crew	Sue Shird	Other Expenses	
Initials	MEM	Review Tech	MAB			SJS		
Employee Class	E3	SET (Str Time)	(Str Time)	PLS	Survey Crew	AA		Task Total
Hourly Rates	\$ 180	\$ 134	\$ 132	\$ 176	\$ 275	\$ 98		Dollars
Construction Phase								
Construction Staking and Bench Marks				6	32		\$530	\$ 10,386
Prepare Contracts for Execution by Contractor and Owner	4					2		\$ 916
Preconstruction Conference (Agenda / Attend / Minutes)	16	3	3			4		\$ 4,070
Attend 3 Progress Meetings (Agendas / Attend / Minutes)	9	3						\$ 2,022
Review Submittals	6	3						\$ 1,482
Construction Review		180	36					\$ 28,872
Process 1 Routine Pay Application Request	3					2		\$ 736
Process Closeout Change Order	8					4		\$ 1,832
Substantial Completion Inspection/Punchlist		4				3		\$ 830
Follow-up Punchlist Inspections/Revised Punchlist		4				1		\$ 634
Prepare Final Quantities	3	3						\$ 942
Project Closeout Documents	3					6		\$ 1,128
CRT Mileage Expenses							\$320	\$ 320
Construction Phase Subtotal (Hours) =	52	200	39	6	32	22	\$850	
Construction Phase Subtotal (Dollars) =	\$ 9,360	\$ 26,800	\$ 5,148	\$ 1,056	\$ 8,800	\$ 2,156	\$ -	\$ 54,170

ESTIMATED CONSTRUCTION COST

Wolf Run Roadway Extension to Western Greenwald Property Line

	Description	Unit	Quantity	Unit Price	Total
1	Mobilization	L.S.	1	\$40,000.00	\$40,000.00
2	Traffic control	L.S.	1	\$5,000.00	\$5,000.00
3	Tracking pad	TON	180	\$30.00	\$5,400.00
4	Project identification signs	L.S.	1	\$2,500.00	\$2,500.00
5	Silt fence	L.F.	950	\$2.00	\$1,900.00
6	Inlet sediment guards, Type D	EA.	4	\$150.00	\$600.00
7	Clearing, grubbing and tree removal	L.S.	1	\$8,000.00	\$8,000.00
8	Full depth saw cutting	L.F.	55	\$3.00	\$165.00
9	CON/SPAN Bridge System	L.F.	1	\$495,000.00	\$495,000.00
10	Construct roadway to subgrade	L.S.	1	\$68,000.00	\$68,000.00
11	Excavation below subgrade	C.Y.	200	\$35.00	\$7,000.00
12	Geotextile subgrade stabilization	S.Y.	600	\$6.00	\$3,600.00
13	Excavation below subgrade (EBS) backfill	TON	400	\$26.00	\$10,400.00
14	Crushed aggregate for road base	TON	2235	\$21.00	\$46,935.00
15	30-inch concrete curb and gutter	L.F.	890	\$16.00	\$14,240.00
16	Asphaltic concrete binder course	TON	425	\$88.00	\$37,400.00
17	Asphaltic concrete surface course	TON	270	\$95.00	\$25,650.00
18	Concrete sidewalk and curb ramp	S.F.	4,580	\$6.00	\$27,480.00
19	Pavement marking, epoxy, 4-inch yellow	L.F.	620	\$2.00	\$1,240.00
20	Topsoil, turf grass seed, fertilizer and Class I, Urban, Type A erosion matting	S.Y.	2,000	\$10.75	\$21,500.00
Sub Total					\$822,010.00
	Administration/ Legal Contingencies			0.2%	\$1,644.02
	Engineering Contingencies			8.0%	\$65,450.00
	Construction Contingencies			10.0%	\$82,201.00
	Construction Administration Contingencies			6.6%	\$54,170.00
Total					\$1,025,475.02

TASK ORDER

This is Task Order No. 2025-05,
consisting of 4 pages.
Village of Mukwonago
Marsh View Drive Extension

Task Order

In accordance with the Agreement Amendment between Village of Mukwonago (Owner) and Ruekert & Mielke, Inc. (Engineer) dated December 21, 2022, Owner and Engineer agree as follows:

1. Specific Project Data

- A. Title: Marsh View Drive Extension
- B. Description: Provide engineering and construction related services for the design, bidding, and construction of the extension of Marsh View Drive.

2. Services of Engineer

Perform certified survey mapping, design services, bidding support, and construction-related services for the dedication and reconstruction of the Marsh View Drive extension. The scope of work includes a detailed topographic survey and the engineering design of approximately 1,010 linear feet of sanitary sewer, 1,340 linear feet of storm sewer, 1,760 linear feet of roadway improvements, including pedestrian access, and water main connection.

Phase 200 – Design and Bidding:

- Prepare and coordinate the overall project schedule,
- Perform site topographic survey, including measure downs,
- Perform and process drone survey and aerial photography,
- Easements, title searches and other property acquisition services,
- Environmental assessment,
- Certified Endangered Resources Review,
- Facilitate 60% design meeting with Village staff and Mr. Greenwald,
- Facilitate 90% design meeting with Village staff and Mr. Greenwald,
- Prepare plan and profile set of drawings along the centerline alignment for proposed sanitary sewer,
- Prepare plan and profile set of drawings along the centerline alignment for proposed water main,
- Prepare plan and profile set of drawings along the centerline alignment for proposed storm sewer,
- Prepare plan and profile drawings along the proposed centerline alignment for proposed roadways, Includes cross-sections plan of drawings,
- Prepare plan of drawings for intersection details,
- Prepare plan of drawings for erosion control,
- Prepare plan of drawings for construction details and construction notes,
- DNR NOI & utility extension permitting.
- WisDOT coordination and permitting,
- Prepare project specifications and other bidding documents,
- Upload bidding documents for online viewing/ordering,
- Answer Contractor questions during bidding period,
- Attend Bid Opening,
- Review bids for completion of all contract requirements. Review prequalification statements, and bidder references,
- Issue Recommendation of Award and Notice of Award,
- Attend Village Board meeting to answer questions about the award of the project.

Phase 320 – Construction Review and Contract Administration Services

- Provide construction review services,
- Administer the construction contract between the Owner and the Contractor. Duties to be performed are itemized in the Construction Contract between the Owner and the Contractor,
- Respond to Owner staff requests for information,

TASK ORDER

- Quantity measurements and quantity coordination with Contractor,
- Coordinate pay request with Owner Staff,
- Coordinate and attend pre-construction meeting,
- Coordinate and attend weekly site meetings,
- Respond to citizen questions during construction,
- Final project closeout.

Phase 610 – GIS Data Updates

- Prepare record drawings to the Owner’s standards.
- Incorporate the utility data into the Owner’s GIS.

Work Available as Additional Services:

The following services are not included in this effort because we have assumed they are not necessary, or the scope of such services has not yet been defined:

- ACOE permitting,
- Wetland delineations,
- Archaeological survey,
- Floodplain analysis and approvals,
- Funding requirements,
- Permit applications not listed,
- Public Information Meetings.

3. Owner’s Responsibilities

The Village will Coordinate with Ruekert & Mielke staff to review draft plans, meet onsite to review layout and attend bid opening. Owner will pay for the cost of the advertisement, Engineer’s reimbursable expenses, reproduction of the bidding documents, distribution of the bidding documents, and will refer all bidders’ questions to the Engineer for response.

4. Times for Rendering Services

<u>Phase</u>	<u>Completion Date</u>
Advertisement for Bid	January 8, 2026
Bid Opening	January 22, 2026
Recommendation of Award	February 4, 2026

5. Payments to Engineer

A. Owner shall pay Engineer for services rendered as follows:

<u>Category of Services</u>	<u>Compensation Method</u>	<u>Estimate of Compensation for Services</u>
Design and Bidding	Lump Sum	\$81,535
Construction Review and Contract Administration Services	Hourly	\$95,240*
GIS Data Updates	Lump Sum	\$1,920

*Services and cost are directly related to the amount of time the selected Contractor takes to complete the project.

TASK ORDER

B. The terms of payment are set forth in the Standard Terms and Conditions.

6. Consultants:

None.

7. Other Modifications to Standard Terms and Conditions:

None.

8. Attachments:

Level of Effort Breakdown for Services and Engineer's Estimated Construction Cost.

9. Documents Incorporated by Reference

Ruekert & Mielke, Inc. / Village of Mukwonago Master Agreement.

TASK ORDER

Task Order No. 2025-05
MARSH VIEW DRIVE EXTENSION
Between Village of Mukwonago
and
Ruekert & Mielke, Inc.
Dated March 24, 2025

Terms and Conditions: Execution of this Task Order by Owner and Engineer shall make it subject to terms and conditions, (as modified above) set forth in the Master Engineering Agreement between Owner and Engineer, dated December 21, 2022, which are incorporated by this reference. Engineer is authorized to begin performance upon its receipt of a copy of this Task Order signed by Owner.

The Effective Date of this Task Order is _____, _____.

OWNER:	ENGINEER:
Village of Mukwonago	Ruekert & Mielke, Inc.
Signature: _____	Signature: _____
Name: _____	Name: <u>Jason P. Lietha, P.E</u>
Title: _____	Title: <u>Senior Vice President</u>
Date: _____	Date: <u>March 24, 2025</u>

DESIGNATED REPRESENTATIVE FOR TASK ORDER

Name: _____	Name: <u>Michael E. Michalski</u>
Title: _____	Title: <u>Project Engineer</u>
Address: _____ _____	Address: <u>W233 N2080 Ridgeview Parkway</u> <u>Waukesha, WI 53188-1020</u>
Email: _____	Email: <u>mmichalski@ruekert-mielke.com</u>
Phone: _____	Phone: <u>262-953-3004</u>
Fax: _____	Fax: <u>262-542-5631</u>

Marsh View Drive Extension

Design and Bidding Estimate

	Peter Gesch	Michael Michalski	Daniel Schwartz	Drafting	Sue Shird	Ecologist / Biologist	Professional Land Surveyor	Survey	Other Expenses	
Initials	PWG	MEM	DJS		SJS					
Employee Class	E5	E4	E4	ET-3	AA	AHH	PLS	Crew		Task Total
Hourly Rates	\$ 195	\$ 175	\$ 184	\$ 149	\$ 95	\$ 160	\$ 171	\$ 267		Dollars
Field Survey										
Perform Site Survey			4					10	\$450	\$ 3,856
Create project in Cad, Format Drawing, Call Diggers, Prep Data for Field Crew, Instructions							6			\$ 1,026
Process Downloads, Analyze Data, Build Surface and Cadastral CSMs, Quit Claim Deed, title searches and other property acquisition services		8	10					3		\$ 2,641
							56	16	\$900	\$ 16,148
Environmental										
Environmental assessment						6				\$ 960
Certified Endangered Resources Review						6				\$ 960
Design										
Prepare and coordinate overall project schedule and route		12								\$ 2,100
Surface, planimetric and profile creation				9						\$ 1,341
Prepare plan and profile set of drawings along the centerline alignment for proposed sanitary sewer		6		12						\$ 2,838
Prepare plan and profile set of drawings along the centerline alignment for proposed water main		2		4						\$ 946
Prepare plan and profile set of drawings along the centerline alignment for proposed storm sewer		24		16						\$ 6,584
Prepare plan and profile drawings along the proposed centerline alignment for proposed roadways, includes cross-sections plan of drawings		28		56						\$ 13,244
Prepare plan of drawings for intersection details		8		16						\$ 3,784
Prepare plan of drawings for erosion control		3		9						\$ 1,866
Prepare plan of drawings for construction details and construction notes		4		12						\$ 2,488
Prepare project specifications and other bidding documents		36			16					\$ 7,820
60% Design Review										
Village of Mukwonago & Mr. Greenwald Review		6		3						\$ 1,497
90% Design Review										
Village of Mukwonago & Mr. Greenwald Review		6		3						\$ 1,497
100% Design Review										
Internal Quality Control Review	6			6						\$ 2,064
Approvals - Regulatory Agencies										
WDNR Sanitary Sewer Extension Permitting						8				\$ 1,280
WDNR Water Main Extension Permitting						8				\$ 1,280
WDNR NOI Permit						12				\$ 1,920
Bidding										
Prepare Advertisement for Bids		2			4				\$600	\$ 1,330
Upload bidding documents for online viewing/ordering					1					\$ 95
Answer Contractor questions during bidding period		2								\$ 350
Attend Bid Opening		2								\$ 350
Evaluate Bids, Prepare Bid Tab		1			4					\$ 555
Assist Village with Contractor References		1								\$ 175
Prepare Recommendation for Award		2			2					\$ 540
Survey, Design and Bidding Phase Subtotal (Hours) =	6	153	14	146	27	40	62	29		
Survey, Design and Bidding Phase Subtotal (Dollars) =	\$ 1,170	\$ 26,775	\$ 2,576	\$ 21,754	\$ 2,565	\$ 6,400	\$ 10,602	\$ 7,743	\$ 1,950	\$ 81,535

Marsh View Drive Extension

Construction Related Services Estimate

	Michael Michalski	Construction	Erosion CRT	Professional Land Surveyor	Survey Crew	Sue Shird	Other Expenses	
Initials	MEM	Review Tech	MAB			SJS		
Employee Class	E3	SET (Str Time)	(Str Time)	PLS	Survey Crew	AA		Task Total
Hourly Rates	\$ 180	\$ 134	\$ 132	\$ 176	\$ 275	\$ 98		Dollars
Construction Phase								
Construction Staking and Bench Marks				8	36		\$660	\$ 11,968
Prepare Contracts for Execution by Contractor and Owner	4					2		\$ 916
Preconstruction Conference (Agenda / Attend / Minutes)	16	3	3			5		\$ 4,168
Attend 8 Progress Meetings (Agendas / Attend / Minutes)	24	8						\$ 5,392
Review Submittals	8	2						\$ 1,708
Construction Review		392	80					\$ 63,088
Process 3 Routine Pay Application Request	9					3		\$ 1,914
Process Closeout Change Order	8					4		\$ 1,832
Substantial Completion Inspection/Punchlist		4				2		\$ 732
Follow-up Punchlist Inspections/Revised Punchlist		4				2		\$ 732
Prepare Final Quantities	3	3						\$ 942
Project Closeout Documents	3					6		\$ 1,128
CRT Mileage Expenses							\$720	\$ 720
Construction Phase Subtotal (Hours) =	75	416	83	8	36	24	\$1,380	
Construction Phase Subtotal (Dollars) =	\$ 13,500	\$ 55,744	\$ 10,956	\$ 1,408	\$ 9,900	\$ 2,352	\$ -	\$ 95,240

ESTIMATED CONSTRUCTION COST

Item #	Description	Unit	Quantity	Unit Price	Total
1	8-inch sanitary sewer in granular backfill	L.F.	1,010	\$120.00	\$121,200.00
2	6-inch sanitary sewer lateral in granular backfill	L.F.	66	\$90.00	\$5,940.00
3	48-inch diameter sanitary sewer manhole	EA.	4	\$3,800.00	\$15,200.00
4	Sanitary sewer manhole bench removal and replacement	EA.	1	\$1,500.00	\$1,500.00
Subtotal Sanitary Sewer					\$143,840.00
5	12-inch water main in granular backfill	L.F.	250	\$160.00	\$40,000.00
6	Remove & Salvage Existing Hydrant Assembly	EA.	1	\$5,000.00	\$5,000.00
7	6-inch Water Service	L.F.	66	\$112.00	\$7,392.00
8	6-inch Water Service Valve	EA.	2	\$3,650.00	\$7,300.00
Subtotal Water Main					\$59,692.00
9	12-inch Class V RCP storm sewer in granular backfill	L.F.	440	\$94.00	\$41,360.00
10	15-inch Class IV RCP storm sewer in granular backfill	L.F.	300	\$84.00	\$25,200.00
11	18-inch Class III RCP storm sewer in granular backfill	L.F.	600	\$88.00	\$52,800.00
12	Catch basin w/12-inch sump	EA.	8	\$2,500.00	\$20,000.00
13	48-inch storm manholes	EA.	6	\$2,500.00	\$15,000.00
Subtotal Storm Sewer					\$154,360.00
14	Land Acquisition *	L.S.	1	\$0.00	\$0.00
15	Construct road to subgrade	LS	1	\$148,000.00	\$148,000.00
16	Crushed aggregate base course	TON	5,750	\$24.00	\$138,000.00
17	2 3/4" Binder course asphaltic pavement	TON	1,115	\$92.00	\$102,580.00
18	1 3/4" Surface course asphaltic pavement	TON	710	\$102.00	\$72,420.00
19	Excavation below subgrade (EBS), if required	C.Y.	650	\$28.00	\$18,200.00
20	Excavation below subgrade (EBS) backfill, if required	TON	1,300	\$32.00	\$41,600.00
21	Geotextile subgrade stabilization, if required	S.Y.	1,950	\$7.00	\$13,650.00
22	30-inch Type D concrete curb and gutter	L.F.	3,540	\$17.00	\$60,180.00
23	Concrete Sidewalk	S.F.	16,000	\$6.50	\$104,000.00
24	Detectable warning field	S.F.	8	\$50.00	\$400.00
25	Concrete Driveway Approach	S.F.	2,000	\$8.00	\$16,000.00
26	Full depth saw cutting	L.F.	350	\$2.75	\$962.50
27	Traffic control	L.S.	1	\$4,000.00	\$4,000.00
28	Inlet protection	EA.	8	\$125.00	\$1,000.00
29	Topsoil, seed, fertilizer	S.Y.	4,400	\$8.00	\$35,200.00
30	Erosion mat	S.Y.	4,400	\$3.00	\$13,200.00
31	Silt Fence	L.F.	700	\$2.50	\$1,750.00
32	Street Lighting	LS	1	\$80,000.00	\$80,000.00
Subtotal Road Construction					\$851,142.50
Sub Total					\$1,209,034.50
Administration and Legal Contingencies				0.7%	\$8,463.24
Engineering Contingencies				6.7%	\$81,005.31
Construction Contingencies				10.0%	\$120,903.45
Construction Administration Contingencies				8.3%	\$100,349.86
Estimated Total Marsh View Project Cost					\$1,519,756.37



Agenda Cover Report

Date: 3/26/25	Committee/Board: Public Works
Submitted by: Ron Bittner	Department: Public Works
Date of Committee Action: 4/2/25	Date of Village Board Action: 4/16/25

Subject: Mukwonago Shared Connectivity Network (MSCN), Fiber Optic MOU
Executive Summary: This proposed Memorandum of Understanding (MOU) was developed after the Mukwonago Area School District approached the village about joint cable installation with a single contractor. Further discussions revealed that sharing fiber optic cable infrastructure could significantly enhance connectivity and technological capabilities for multiple organizations. By pooling resources, members can access high-speed internet and advanced communication networks without bearing the full cost individually. Sharing fiber optic cable infrastructure is a strategic and efficient way to leverage technology for the benefit of all involved. The partnership and its network shall be referred to as the Mukwonago Shared Connectivity Network (MSCN), which aptly captures the collaborative nature of the fiber network among the members.

Attachments Included



Memorandum of Understanding

This MEMORANDUM OF UNDERSTANDING ("MOU") is made and entered into by and among the Mukwonago Area School District, the Village of Mukwonago, and the Mukwonago Community Library, hereinafter referred to as "Member(s)."

1. Purpose:

Sharing fiber optic cable infrastructure can significantly enhance connectivity and technological capabilities for multiple organizations. By pooling resources, entities such as schools, municipalities, and libraries can access high-speed internet and advanced communication networks without bearing the full cost individually. This collaborative approach not only reduces expenses but also fosters a sense of community and cooperation. Additionally, shared fiber optic networks can lead to improved maintenance and upgrades, as the responsibility is distributed among the participating parties, ensuring that the infrastructure remains in optimal condition. Overall, sharing fiber optic cable infrastructure is a strategic and efficient way to leverage technology for the benefit of all involved. The partnership and its network shall be referred to as **Mukwonago Shared Connectivity Network (MSCN)**, which nicely captures the collaborative nature of the fiber network among the Members.

This MOU sets forth the terms and understanding among the Members regarding the utilization of equipment and facilities related to fiber optic transmission lines and the provision of access to Information Technology (IT) closets for qualified representatives from any of the Members.

2. Scope:

a. Utilization of Equipment and Facilities:

- The Village of Mukwonago and Mukwonago Area School District own, operate and maintain fiber optic transmission cable.
- The parties agree to share and utilize the equipment and facilities related to fiber optic transmission lines to enhance connectivity and technological capabilities.
- Each party will ensure that the equipment and facilities are maintained in good working condition and used responsibly.

b. Access to IT Closets:

- Qualified representatives from any of the parties will be granted access to IT closets as needed to perform necessary maintenance, upgrades, and troubleshooting.



- Access will be coordinated and scheduled in advance to minimize disruptions and ensure security.

3. Responsibilities:

a. Mukwonago Area School District:

- Provide access to IT closets located within school district properties.
- Ensure that representatives are qualified and adhere to security protocols.
- Maintain and provide quality fiber cable infrastructure.
- Promptly notify all parties on system repairs and/or service.

b. Village of Mukwonago:

- Provide access to IT closets located within village properties.
- Ensure that representatives are qualified and adhere to security protocols.
- Maintain and provide quality fiber cable infrastructure.
- Promptly notify all parties on system repairs and/or service.

c. Mukwonago Community Library:

- Provide access to Village owned and operated equipment and cabling within IT closets and library buildings.
- Ensure that representatives are qualified and adhere to security protocols.

4. Maintenance:

Each Member will be responsible for the performance and cost of their entity's own maintenance, repair, and updates to the MSCN, including but not limited to locating, engineering assistance, break-fix charges, relocation costs, network enhancements and dedicated fiber optic expansion. The Members agree that they shall perform such maintenance, repair, and updates as reasonably necessary, and in a reasonable manner and time frame, for the efficient operation of the MSCN.

5. Unplanned Outages:

Unplanned outages may occur from time to time due to various circumstances and will be repaired as soon as reasonably possible by the Member responsible for the outage or the portion of the MSCN causing the outage. No Member shall be held liable, financially or otherwise, to the other Member for any unplanned outages that may occur, unless such



outages are the result of a Member's gross negligence or willful conduct. It is in the best interest of all Members to maintain maximum uptime for the MSCN and connection. Repairs shall be completed as soon as reasonably possible with the expectation that most repairs will be completed within twenty-four (24) hours of notice that the outage has occurred.

6. Planned Outages:

- a. A Member planning an outage or potential outage that would affect connectivity of any of the other Members shall provide thirty (30) days' prior notice via email to the other Members when possible, but under no circumstances shall such email notice be provided less than sixty (60) hours prior to the planned outage. This includes but is not limited to, equipment upgrades, equipment maintenance, fiber optic network upgrades, and fiber optic network maintenance.
- b. Planned outages must be coordinated for a specific time and date, preferably after normal business hours. No planned outage may occur without the Member giving notice under subsection (a) and receiving acknowledgement and confirmation from the other Members that such notice has been delivered. The notice requirements under Section 8 shall not apply to notices required under this section.

7. Term and Termination:

- a. This MOU will be effective as of the date of the last Member's signature to this MOU and shall remain in effect for two (2) years from the date of the last signature ("Term"), unless terminated earlier as provided herein. This MOU shall automatically renew at the end of the Term for an unlimited number of successive two (2) year terms unless any Member provides written notice at least twelve (12) months prior to the end of the Term, or any renewal term thereafter, of such Member's decision not to automatically renew this MOU.
- b. In the event any Member should: (i) neglect, refuse, or fail to perform under the material provisions of this MOU; or (ii) disregard applicable laws; or (iii) violate any material provision of this MOU, any other Member may at any time upon six (6) months written notice to the offending Member, without prejudice to any other right or remedy which it may have for damages resulting therefrom, treat the same as a material breach of this MOU and terminate this MOU.
- c. Upon termination, the terminating Member will no longer be able to utilize assets contributed to the MSCN by the remaining Members.



8. Contacts and Notices:

- a. Each Member shall provide minimally two (2) contacts who will serve as "all hours" contacts for the MSCN. Contact information including names, phone numbers and email addresses shall be kept current and provided to the other Members. In the event a contact changes, the Member shall provide the information of the new contact to the other Members via email.
- b. Unless otherwise provided in this MOU, all notices, demands, requests, consents, approvals, or other instruments required or permitted to be given by any Member pursuant to this MOU shall be in writing and shall be deemed to have been properly given if sent by commercial courier or certified mail, postage prepaid, with return receipt requested, to the other Members at their respective addresses for notices. Any notices, demands, requests, consents, approvals, or other instruments sent to any Members under this subsection (b) shall also be given via email as a courtesy, but any failure to do so shall not deem such instruments to have not been served correctly if otherwise properly sent under this subsection (b). The contact information for notices shall be as follows:

Mukwonago Area School District

Address: 385 E. Veterans Way, Mukwonago, WI 53149
Contact Person: Tom Karthausser, Chief Financial Officer
Contact Information: (262) 363-6300, karthto@masd.k12.wi.us

Village of Mukwonago

Address: 440 River Crest Court, Mukwonago, WI 53149
Contact Person: Ron Bittner, Public Works Director
Contact Information: (262) 363-6447, rbittner@villageofmukwonago.gov

Mukwonago Community Library

Address: 511 Division Street, Mukwonago, WI 53149
Contact Person: Abby Armour, Library Director
Contact Information: (262) 363-6411, aarmour@mukwonagolibrary.org

Notice shall be deemed given two (2) business days after mailing. The addresses for notices may be changed by the Members from time to time by delivery of written notice to the other Members.

9. Miscellaneous:

- a. Each Member represents and warrants the use and access by its employees, officers, agents, and end users of the MSCN shall comply with all applicable laws, ordinances, rules, regulations and restrictions, including without limitation those related to privacy and electronic communications. Each Member agrees to cooperate with



the others in complying with any requirements applicable to their respective rights and obligations under this MOU that are imposed by any governmental agency, regulatory agency or authority. Any non-compliant Member must meet with the other Members to discuss and attempt remedying the non-compliance. A non-compliant Member may lose connectivity to MSCN assets and benefits if compliance is not achieved within a reasonable time period, as determined by the other Members. Nothing in this paragraph shall prevent either Member from exercising its right to terminate for breach under Section 7 of this MOU.

- b. Annual meetings may be conducted among the Members on a mutually agreed upon date, or more frequently if determined necessary by the Members. The purpose of the meetings will be to review items such as bandwidth speeds and necessary upgrades to the MSCN, as well as to discuss any other matters the Members wish to address.
- c. Each Member ("Indemnifying Member" for purposes of this paragraph) releases and agrees to indemnify, defend, and hold harmless the other Members, including the others' employees, officers, governing bodies and members thereof, and agents, from and against any claim against the other Members directly resulting from or in connection with:
 - I. any injury, loss or damage to any person, tangible property or facilities of any third party including reasonable attorneys' fees and costs to the extent the same arise out of or result from (1) the negligent acts or omissions of the Indemnifying Member; and/or (2) a material breach of this MOU by the Indemnifying Member; and/or
 - II. any claims, liabilities or damages directly arising out of any violation of the Indemnifying Member of any regulation, rule, statute or order of any local, state or federal governmental agency, court or other governing authority in connection with the performance of the Indemnifying Member's obligations under this MOU.

The Members agree to promptly provide each other with written notice of any lawsuit, judicial, administrative or other dispute resolution action or proceeding or claim of which it becomes aware and which may result in an indemnification obligation of the other Member under this MOU.

- d. Nothing contained in this MOU is intended to be a waiver or estoppel of the Members or their insurers to rely upon the limitations, defenses, and immunities contained within Wisconsin Statutes Section 893.80. To the extent that indemnification is available and enforceable, the Members or their insurers shall not be liable in indemnity, contribution or otherwise for an amount greater than the limits of liability of municipal claims established by law. Under no circumstances shall a Member be required to indemnify the other Members for the other Members' own negligence or intentional conduct.



- e. Each Member shall, during the term of this MOU, procure and maintain general liability insurance coverage, at its own cost, in amounts reasonably adequate to cover liability for damages arising out of the Members' respective use, repair and maintenance of the MSCN. If requested, any Member shall promptly provide the others with copies of certificates of insurance and policy endorsements. Each such policy shall name the other Members as additional insureds under said policy on a primary and noncontributory basis.
- f. If any of the terms or provisions contained herein shall be declared to be invalid or unenforceable by a court of competent jurisdiction, then the remaining provisions and conditions of this MOU shall remain in full force and effect, and shall be valid and enforceable to the fullest extent permitted by law.
- g. This MOU constitutes the entire agreement between the Members with respect to the subject matter hereof, and there are no other representations, warranties, or agreements except as herein provided.
- h. This MOU may be executed in one or more counterparts, each of which shall be deemed an original.
- i. The terms and conditions of this MOU shall be binding upon and benefit the Members hereto and their respective successors.
- j. Nothing in this MOU shall be construed as creating a joint venture or partnership between the Members.
- k. The Members may not assign this MOU or any rights, interest or obligations herein. The Members may not permit the use of the MSCN by another person or entity without the prior written consent of the other Members.
- l. Any failure by any Member to insist upon the performance of any provision of this MOU shall not constitute a waiver of any rights under the MOU or future performance of that provision.
- m. This MOU shall be governed by and construed in all respects in accordance with the laws of the State of Wisconsin. Any legal action regarding the terms of this MOU shall be brought and maintained in the Circuit Court for Waukesha County, WI.
- n. This MOU may be modified, changed, altered or amended only by express, written agreement among the Members.
- o. The persons signing on behalf of each Member hereby warrant and represent that they have authority to execute this MOU on behalf of the Member for whom they have signed.



Mukwonago Area School District

By: _____

Date: _____

Name: _____

Title: _____

Village of Mukwonago

By: _____

Date: _____

Name: _____

Title: _____

Mukwonago Community Library

By: _____

Date: _____

Name: _____

Title: _____



Agenda Item Cover Report

Date: 3-24-25	Committee/Board: Public Works
Submitted by: Wayne Castle	Department: Wastewater
Date of Committee Action: 4-2-25	Date of Village Board Action: 4-16-25

Subject: Sewer Credit Request for 419 Lake St.
<p>Executive Summary:</p> <p>During meter reading we discovered a higher than normal usage from the customer. While leaving a card notifying the customer, utilities staff observed a yard hydrant that was leaking. The staff member took a picture and tried to shut off the yard hydrant to stop the leak. Unfortunately, it would not shut off. Customer reached out to us about a week later after noticing the leak and shutting it off inside the home. Customer states that they then found our card must have blown off the door and into the nearby bushes.</p>
<p>Fiscal Impact:</p> <p>None</p>
<p>Executive Recommendation/Action:</p> <p>Provide a credit for the sewer usage to account for the water not going down the sewer.</p>

Attachments Included